

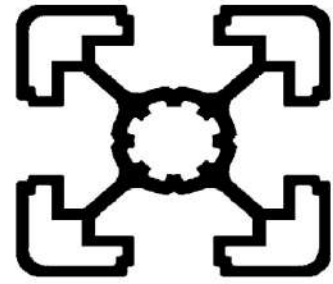

Aluminium Profile System



Automation



Version : 10.24



Order code: 999.....



INDEX

Aluminium Profiles	4-20	Feet	70-72
Telescopic Profile	22	Castors Wheels	73-75
CNC Bed Profile	23	Transport and Base Plates	76
Cover Profiles	25	Aluminium Hinges	78
Cover Caps	26-31	Plastic Hinges	79-80
Brackets	33-37	Handles	81-83
Table Clamp	37	Ball Catch and Magnet Catch	83-84
Feet Bracket	38	Slam Latch	84
Cubic Connectors	39-41	Sliders	85
Corner Brackets	41-42	Roller	86-87
3 Way Connectors	43	Panel & Rubber Profile	88
T Connectors	44	Uniblocks	89-90
Floor Bracket	44	Tool Hanger	92
Central Bolts	45	Worktables	93-95
Thread Forming Central Bolt	45	T Bolts	98-99
Quick Connectors	46-47	Flange Nut	100
Inner Brackets	47-48	T Nuts(HAMMER NUT)	100-101
Bolt Connectors	49	Slot Nut(SQ NUT)	101-102
Universal Connectors	50	Rhombus Nut	102
Plates	51-53	Roll-in T Slot Nut	103
45° Connectors	54-55	Screws & Reducer	105-106
Angle Connectors	55-56	Cable Binder	107
Profile Connectors	57-59	Grinder Stone	109
Any Degree Connectors	60	Forming Tool	109
Fence Mount Base	61-62	Drilling Device	109
Swivel Brackets	64	Profile Cutting Machine	110
Pivot Joint	65-67		
Pivoting Brackets	68		
Clamp Lever	68		

Aluminium Profile
Cover Profile
Cover cap



1

Connectors
Joints



2

Feet
Wheels
Base Plates



3

Door and Panel
Elements



4

Workstation
Equipment



5

Fixing and
Installation
Materials



6

Tools and
Profile Cutting
Machine



7

4 AUTOMATION



ALUMINIUM PROFILES

General



Material Al 6063 T6
Tensile strength $\geq 220 \text{ N/mm}^2$
Natural anodized 10-15 μm
Length 6M

General



15x30, 15x120, 18x100 CNC Bed Profile
20x20 T-Slot, 20x40 T-Slot, 20x60 T-Slot
20x20 V-Slot, 20x40 V-Slot, 20x40x80 V-Slot
20x20 R
30x30, 30x30 R, 30x30 2-Slot(2 Side Closed)
30x60, 30x90
40x40, 40x40 1-Slot(3 Side Closed)
40x40 2-Slot(2 Side Closed)
40x40 3-Slot(1 Side Closed)
40x40 R, 40x40 H, 40x40 L
40x80, 40x120, 40x160
45x45, 45x45 1-Slot(3 Side Closed)
45x45 2-Slot(2 Side Closed)
45x45H, 45x45 L
45x45 R, 45x60, 45x90, 45x90 H
50x50, 50x100
60x60 4-Slot, 60x60 4-SlotH, 60x60 8-Slot
60x120 Slot-8
80x80, 80x120, 80x160
90x90, 100x100

ALUMINIUM PROFILES

Profile 15x30



999 100 038

Quantity/Box 192M
 Weight/M 0.567 kgs
 Weight/Box 56 kgs
 Moment of Inertia (Ix) 0.8cm⁴
 (Iy) 0.8cm⁴
 Profile Surface 211mm²

Application:

Machinery
 3D Printers

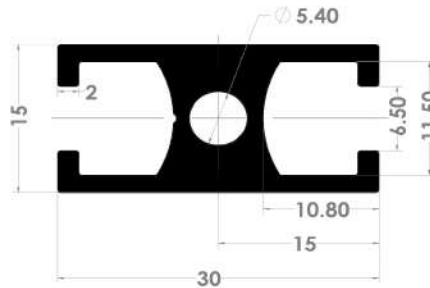

1

Profile 15x120



999 100 001

Quantity/Box 48M
 Weight/M 2.11kgs
 Weight/Box 101kgs
 Moment of Inertia (Ix) 110.4cm⁴
 (Iy) 2.2cm⁴
 Profile Surface 794mm²

Application:

Machinery
 3D Printers

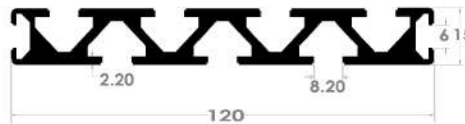

Profile 20x20 T-Slot



999 100 002

Quantity/Box 216M
 Weight/M 0.420kgs
 Weight/Box 92kgs
 Moment of Inertia (Ix) 0.7cm⁴
 (Iy) 0.7cm⁴
 Profile Surface 146mm²

Application:

Decorations
 workstations
 Machinery
 Automation parts

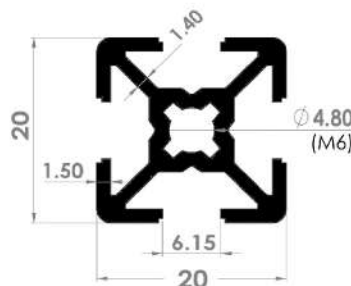

DRILL Ø4.2mm For M5 Tap

DRILL Ø5mm For M6 Tap



6 AUTOMATION



ALUMINIUM PROFILES

999 100 045

Profile 20x20 T-Slot Radius

1

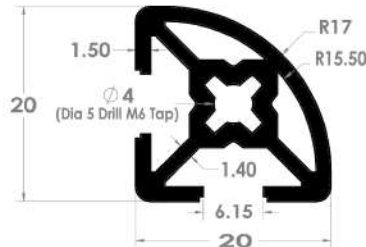
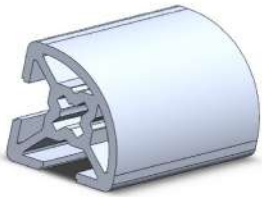

DRILL Ø5mm For M6 Tap

Quantity/Box	216M
Weight/M	0.429kgs
Weight/Box	94 kgs
Moment of Inertia	(Ix)0.65cm ⁴ (Iy)0.65cm ⁴
Profile Surface	297.18mm ²

Application:

Robot Frame
Automation parts

999 100 004

Profile 20x40T-Slot

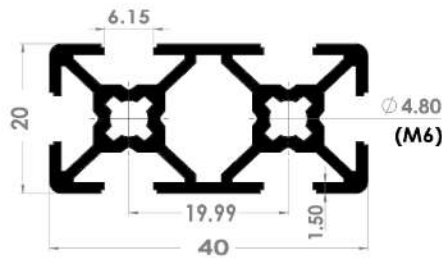

DRILL Ø5mm For M6 Tap

Quantity/Box	108M
Weight/M	0.75kgs
Weight/Box	83kgs
Moment of Inertia	(Ix) 4.6cm ⁴ (Iy) 1.2cm ⁴
Profile Surface	279mm ²

Application:

Robot Frame
Automation parts

999 100 034

Profile 20x60 T-Slot

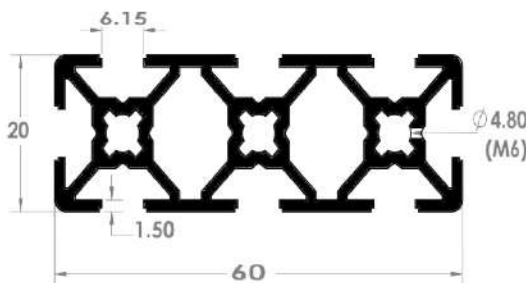

DRILL Ø5mm For M6 Tap

Quantity/Box	72M
Weight/M	1.09 kgs
Weight/Box	81kgs
Moment of Inertia	(Ix)13.9cm ⁴ (Iy)1.5cm ⁴
Profile Surface	406.3 mm ²

Application:

Robot Frame
Automation parts

ALUMINIUM PROFILES

Profile 20x20 V-Slot

999 100 003

Quantity/Box 216M
 Weight/M 0.442kgs
 Weight/Box 97 kgs
 Moment of Inertia (Ix) 0.7cm⁴
 (Iy) 0.7cm⁴
 Profile Surface 132mm²

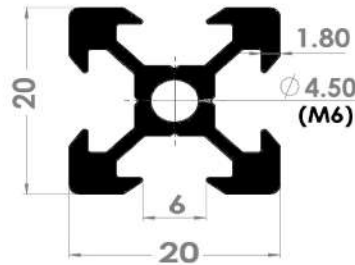

DRILL Ø5mm For M6 Tap

Application:

Decorations
 workstations
 Machinery
 Automation parts

1

Profile 20x40V-Slot

999 100 005

Quantity/Box 108M
 Weight/M 0.75kgs
 Weight/Box 83kgs
 Moment of Inertia (Ix) 4.6cm⁴
 (Iy) 1.2cm⁴
 Profile Surface 289mm²

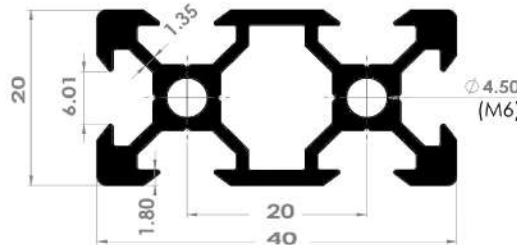

DRILL Ø5mm For M6 Tap

Application:

Robot Frame
 Automation parts

Profile 20x40x80 V-Slot C Type

999 100 036

Quantity/Box 30M
 Weight/M 2.03kgs
 Weight/Box 62kgs
 Moment of Inertia (Ix) 48.31cm⁴
 (Iy) 21.42cm⁴
 Profile Surface 754mm²

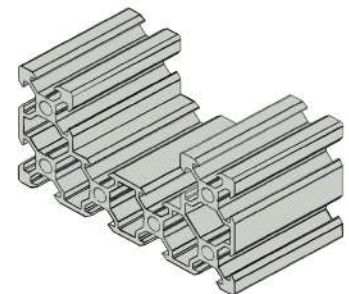
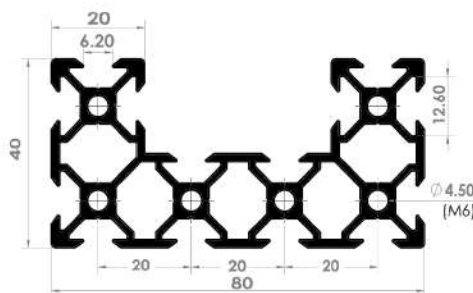

DRILL Ø5mm For M6 Tap

Application:

Robot Frame
 Automation parts

ALUMINIUM PROFILES

1

999 100 006 Profile 30x30

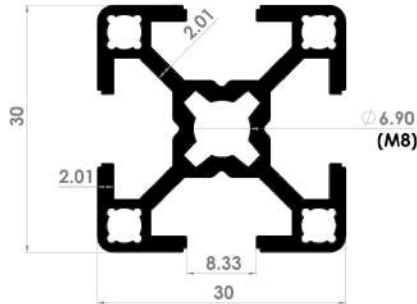

Quantity/Box	96M
Weight/M	0.763kgs
Weight/Box	75kgs
Moment of Inertia	(Ix) 2.7 cm ⁴ (Iy) 2.7 cm ⁴
Profile Surface	284mm ²

Application:

- Machine cover
- Show board
- Design Line

999 100 007 Prfoile 30x30R

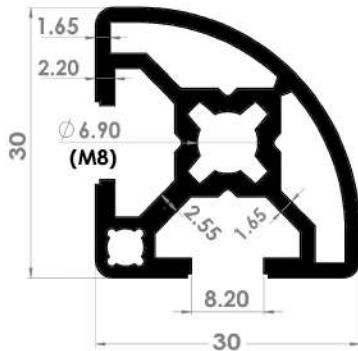

Quantity/Box	96M
Weight/M	0.76kgs
Weight/Box	25kgs
Moment of Inertia	(Ix) 2.4 cm ⁴ (Iy) 2.4 cm ⁴
Profile Surface	300mm ²

Application:

- Light weight
- Tripods
- Laboratory Fixtures
- Cover cap

999 100 008 Profile 30x30 2-Slot(2Side Closed)

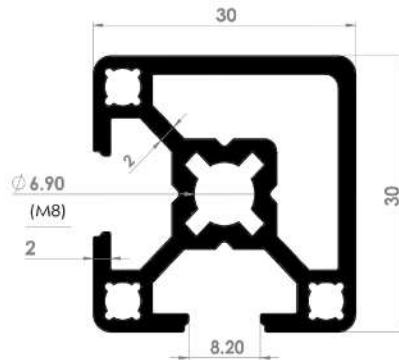

Quantity/Box	96M
Weight/M	0.859kgs
Weight/Box	84kgs
Moment of Inertia	(Ix) 3.1 cm ⁴ (Iy) 3.1 cm ⁴
Profile Surface	333mm ²

Application:

- Light structures
- Enclosures
- Workstations

9 AUTOMATION



ALUMINIUM PROFILES

Profile 30x60



999 100 009

1

Quantity/Box 48M
 Weight/M 1.40kgs
 Weight/Box 69kgs
 Moment of Inertia (Ix) 18.8cm⁴
 (Iy) 6.0cm⁴
 Profile Surface 1002mm²

Application:

Assembly line
 Flat belt conveyor
 Machine cover

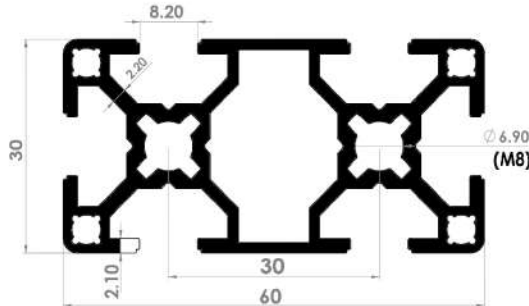

Profile 30x90



999 100 035

Quantity/Box 36M
 Weight/M 1.99 kgs
 Weight/Box 73 kgs
 Moment of Inertia (Ix) 58.2cm⁴
 (Iy) 7.5cm⁴
 Profile Surface 739mm²

Application:

Assembly line
 work station
 Table
 Protection barrier

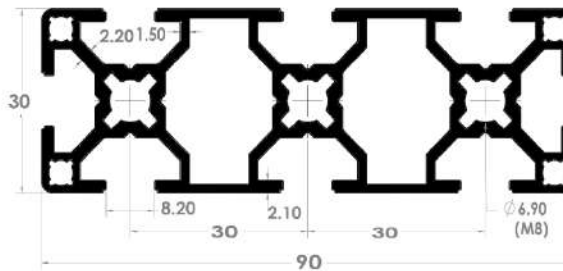

Profile 40x40



999 100 010

Quantity/Box 54M
 Weight/M 1.16kgs
 Weight/Box 64kgs
 Moment of Inertia (Ix) 7.9cm⁴
 (Iy) 7.9cm⁴
 Profile Surface 430mm²

Application:

Assembly line
 work station
 Table
 Protection barrier

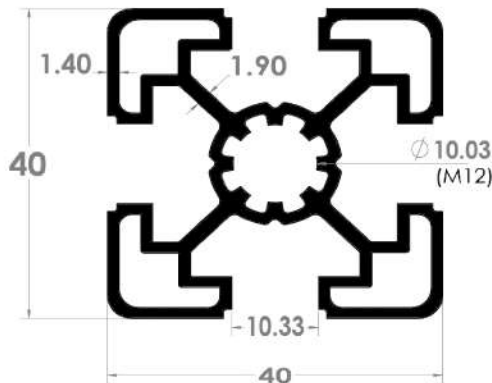

ALUMINIUM PROFILES

999 100 046 40x40 Light

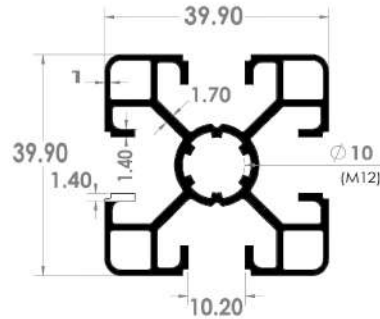
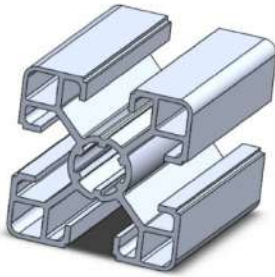

Quantity/Box	54M
Weight/M	1.047kgs
Weight/Box	58kgs
Moment of Inertia	(Ix) 6.2 cm^4 (Iy) 6.2 cm^4
Profile Surface	387.81mm ²

Application:

Assembly line
Workstation
Table

1

999 100 011 Profile 40x40 1-Slot (3 Side Closed)

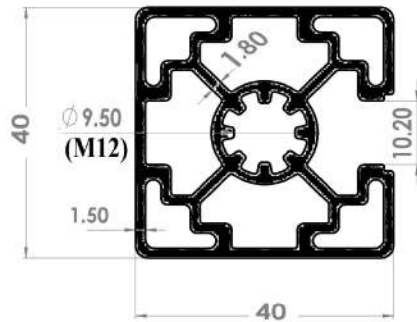

Quantity/Box	54M
Weight/M	1.44kgs
Weight/Box	80kgs
Moment of Inertia	(Ix) 9.8 cm^4 (Iy) 10.3 cm^4
Profile Surface	533mm ²

Application:

Assembly line
Workstation
Table

999 100 012 Profile 40x40 2-Slot (2 Side Closed)

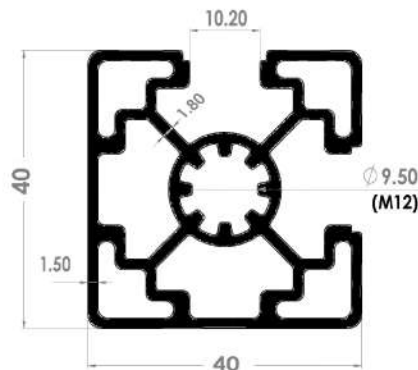

Quantity/Box	54M
Weight/M	1.39kgs
Weight/Box	77kgs
Moment of Inertia	(Ix) $9,7\text{ cm}^4$ (Iy) $9,7\text{ cm}^4$
Profile Surface	515mm ²

Application:

Assembly line
Workstation

11 AUTOMATION



ALUMINIUM PROFILES

Profile 40x40 3-Slot(1 Side Closed) 

999 100 013

1

Quantity/Box 54M
 Weight/M 1.21kgs
 Weight/Box 67kgs
 Moment of Inertia (Ix) 9,7 cm⁴
 (Iy) 9,0 cm⁴
 Profile Surface 447mm²

Application:

Assembly line
 Workstation
 Table

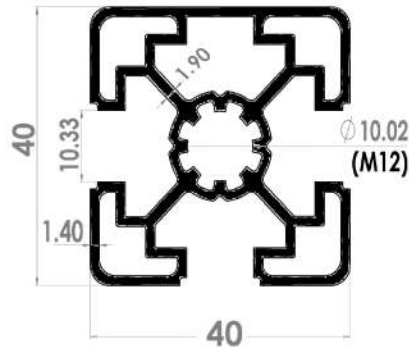

Profile 40x40 R 

999 100 014

Quantity/Box 24M
 Weight/M 1.09kgs
 Weight/Box 35kgs
 Moment of Inertia (Ix) 7,2 cm⁴
 (Iy) 7,2 cm⁴
 Profile Surface 405mm²

Application:

Work bench
 Table
 machine cover
 Design line

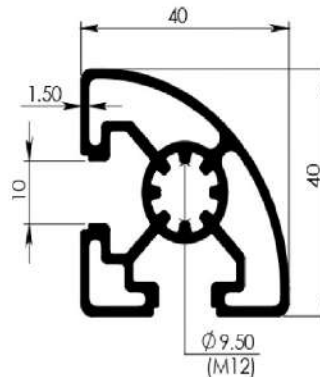

Profile 40x40 Heavy 

999 100 015

Quantity/Box 54M
 Weight/M 1.56kgs
 Weight/Box 86kgs
 Moment of Inertia (Ix) 12,1 cm⁴
 (Iy) 12,1 cm⁴
 Profile Surface 581mm²

Application:

Heavy rigid machine frame
 work bench

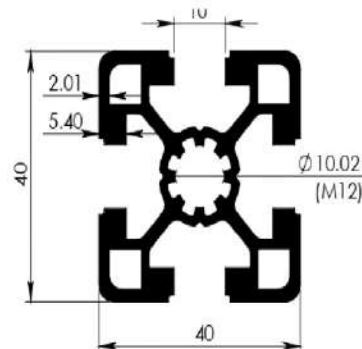

ALUMINIUM PROFILES

999 100 016



Profile 40x80

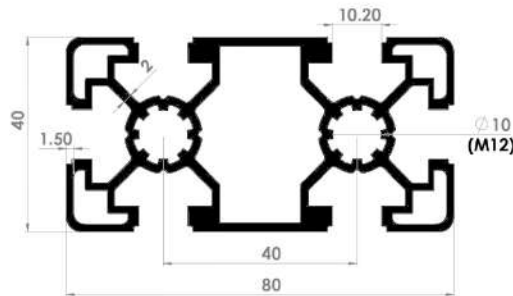

Quantity/Box	30M
Weight/M	2.29kgs
Weight/Box	57kgs
Moment of Inertia (Ix)	59,6cm ⁴
Moment of Inertia (Iy)	16,3cm ⁴
Profile Surface	849mm ²

Application:

Rigid machine frame
work bench

1

999 100 043

Profile 40x80 Heavy

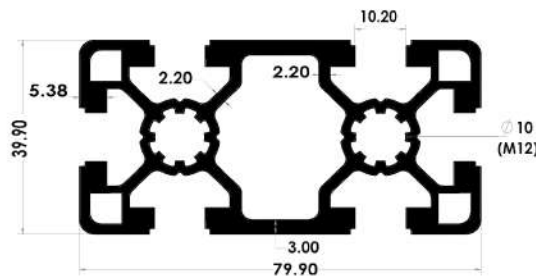
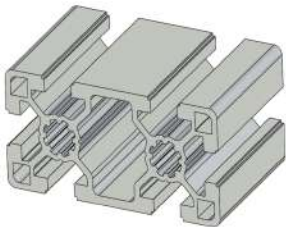

Quantity/Box	30M
Weight/M	2.76 kgs
Weight/Box	84 kgs
Moment of Inertia (Ix)	94 cm ⁴
Moment of Inertia (Iy)	25.95cm ⁴
Profile Surface	1021.99 mm ²

Application:

Light weight
Tripods
Laboratory Fixtures
Cover cap

999 100 019

Profile 45x45

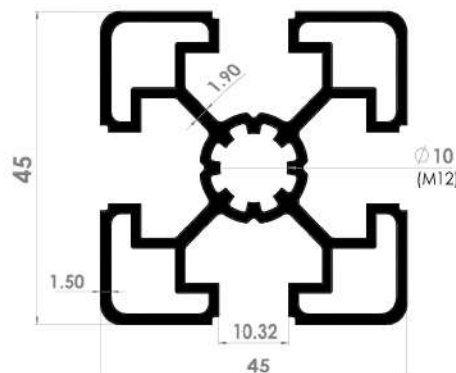

Quantity/Box	54M
Weight/M	1.35kgs
Weight/Box	66kgs
Moment of Inertia (Ix)	11,0cm ⁴
Moment of Inertia (Iy)	11,0cm ⁴
Profile Surface	498mm ²

Application:

Assembly line
work station
Table
Protection barrier
Machine cover

ALUMINIUM PROFILES

Profile 40x120



999 100 017

Quantity/Box 18M
 Weight/M 3.18kgs
 Weight/Box 59kgs
 Moment of Inertia (Ix) 203,2cm⁴
 (Iy) 27,8cm⁴

Profile Surface 1177mm²

Application:

Light weight
 Tripods
 Laboratory Fixtures
 Cover cap

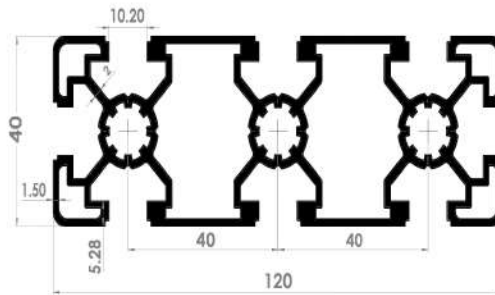

1

Profile 40x160



999 100 018

Quantity/Box 12M
 Weight/M 4.9kgs
 Weight/Box 90kgs
 Moment of Inertia (Ix) 446.7cm⁴
 (Iy) 37cm⁴

Profile Surface 1816mm²

Application:

Light weight
 Tripods
 Laboratory Fixtures
 Cover cap

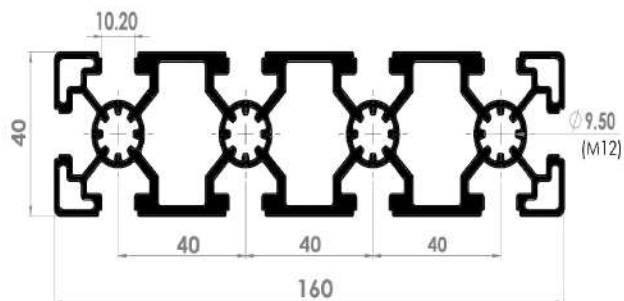

Profile 45x45



999 100 019

Quantity/Box 54M
 Weight/M 1.35kgs
 Weight/Box 66kgs
 Moment of Inertia (Ix) 11,0cm⁴
 (Iy) 11,0cm⁴

Profile Surface 498mm²

Application:

Assembly line
 work station
 Table
 Protection barrier
 Machine cover

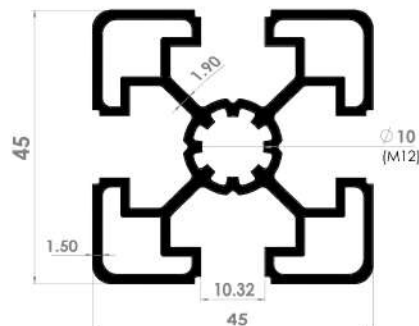

ALUMINIUM PROFILES

999 100 047

45x45 Light



1

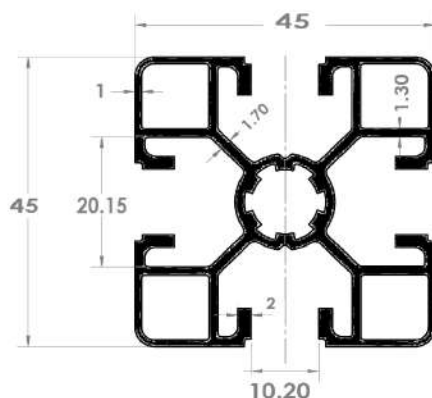
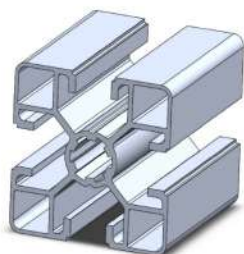

Quantity/Box	54M
Weight/M	1.209kgs
Weight/Box	68kgs
Moment of Inertia (Ix)	9.1cm ⁴
(Iy)	9.1cm ⁴
Profile Surface	447.98 mm ²

Application:

- Protection barrier
- Light weight design
- Table
- Exhibition stand construction
- Design line

999 100 020

Profile 45x45 1-Slot(3 Side Closed)

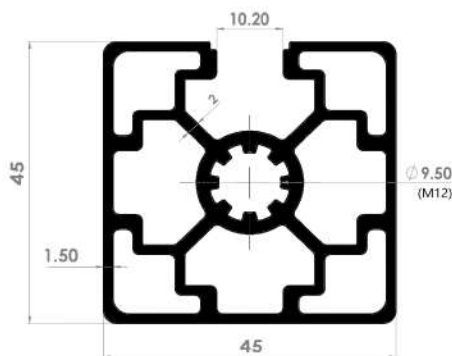

Quantity/Box	54M
Weight/M	1.67kgs
Weight/Box	60.12kgs
Moment of Inertia (Ix)	13.5cm ⁴
(Iy)	13.4cm ⁴
Profile Surface	619mm ²

Application:

- Protection barrier
- Light weight design
- Table
- Exhibition stand construction
- Design line

999 100 021

Profile 45x45 2-Slot(2 Side Closed)

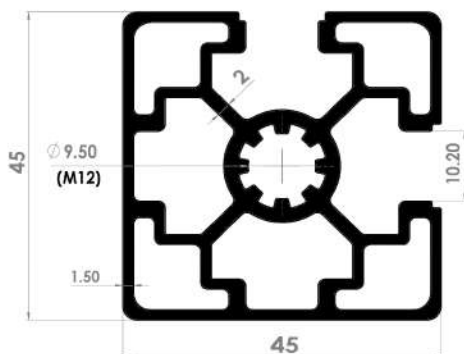

Quantity/Box	54M
Weight/M	1.62kgs
Weight/Box	70kgs
Moment of Inertia (Ix)	13.7cm ⁴
(Iy)	13.7cm ⁴
Profile Surface	601mm ²

Application:

- Light weight
- Tripods
- Laboratory Fixtures
- Cover cap

ALUMINIUM PROFILES

Profile 45x45 Heavy



999 100 022

Quantity/Box	48M
Weight/M	1.95kgs
Weight/Box	72kqs
Moment of Inertia	(Ix) 13.8cm ⁴ (Iy) 13.8cm ⁴
Profile Surface	724mm ²

Application:

Light weight
 Tripods
 Laboratory Fixtures
 Cover cap

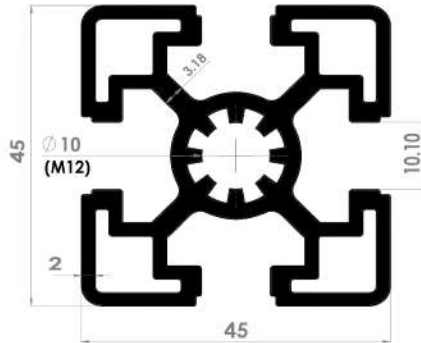

1

Profile 45x45R



999 100 023

Quantity/Box	24M
Weight/M	1.30kgs
Weight/Box	72kqs
Moment of Inertia	(Ix) 8.8cm ⁴ (Iy) 8.8cm ⁴
Profile Surface	482mm ²

Application:

Light weight
 Tripods
 Laboratory Fixtures
 Cover cap

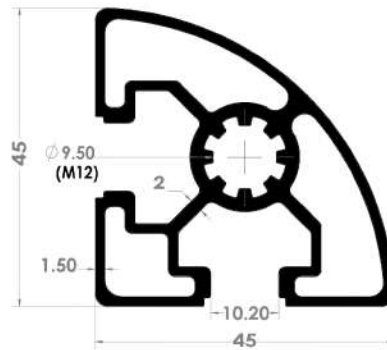

Profile 45x60



999 100 024

Quantity/Box	24M
Weight/M	2.51kgs
Weight/Box	62kqs
Moment of Inertia	(Ix) 37.23cm ⁴ (Iy) 22.83cm ⁴
Profile Surface	932mm ²

Application:

Light weight
 Tripods
 Laboratory Fixtures
 Cover cap

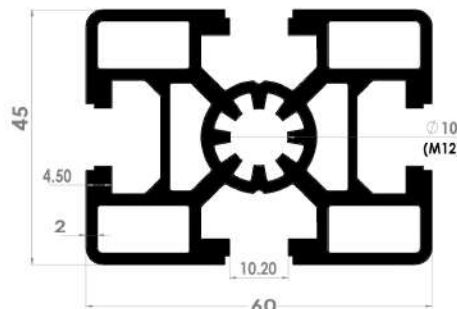

ALUMINIUM PROFILES

999 100 025

Profile 45x90



1

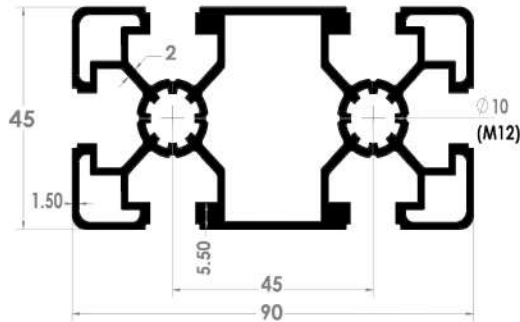

Quantity/Box	24M
Weight/M	2.55 kgs
Weight/Box	62.5 kgs
Moment of Inertia	(Ix) 84,2cm ⁴ (Iy) 23,7cm ⁴
Profile Surface	945.36mm ²

Application:

Rigid machine frame
Work bench
Robot cell

999 100 042

Profile 45x90 Heavy

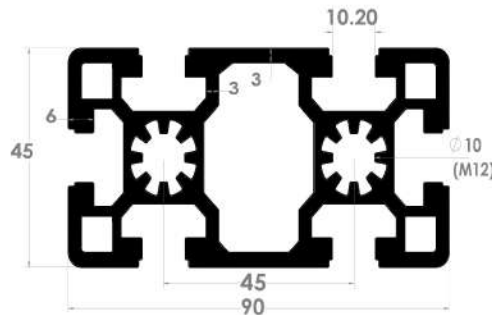
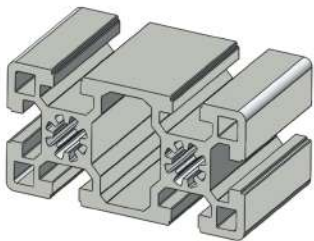

Quantity/Box	24M
Weight/M	4.04kgs
Weight/Box	98kgs
Moment of Inertia	(Ix)120.2cm ⁴ (Iy)30.7cm ⁴
Profile Surface	1498.99mm ²

Application:

Light weight
Tripods
Laboratory Fixtures
Cover cap

999 100 026

Profile 50x50

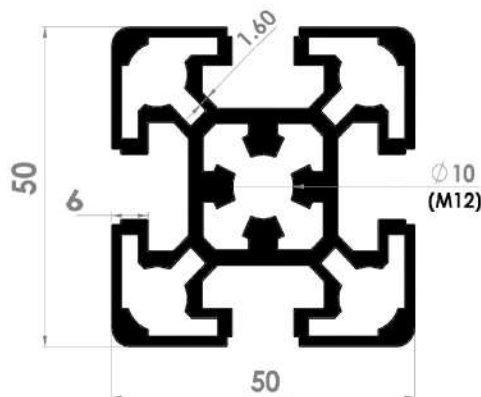

Quantity/Box	24M
Weight/M	2.35kgs
Weight/Box	72kgs
Moment of Inertia	(Ix) 22.18cm ⁴ (Iy) 22.18cm ⁴
Profile Surface	866mm ²

Application:

Light weight
Tripods
Laboratory Fixtures
Cover cap

ALUMINIUM PROFILES

Profile 50x100



999 100 027

Quantity/Box	24M
Weight/M	4.1 kgs
Weight/Box	100kgs
Moment of Inertia	(Ix) 162,8cm ⁴ (Iy) 42,2 cm ⁴
Profile Surface	1465mm ²

Application:

- Light weight
- Tripods
- Laboratory Fixtures
- Cover cap

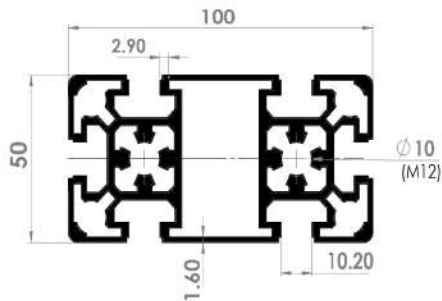

1

Profile 60x60-4 Slot



999 100 028

Quantity/Box	24M
Weight/M	2.56kgs
Weight/Box	63kgs
Moment of Inertia	(Ix) 38,7 cm ⁴ (Iy) 38,7 cm ⁴
Profile Surface	1010mm ²

Application:

- Rigid machine frame
- Work bench
- Robot cell

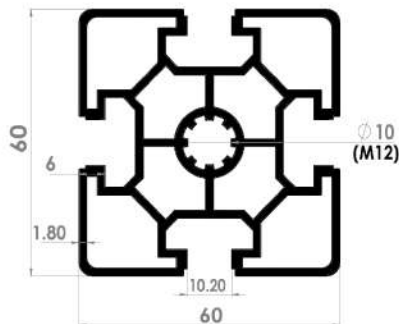

Profile 60x60 4-Slot Heavy



999 100 037

Quantity/Box	24M
Weight/M	3.5 kgs
Weight/Box	85 kgs
Moment of Inertia	(Ix) 50.3 cm ⁴ (Iy) 50.3 cm ⁴
Profile Surface	1296.38 mm ²

Application:

- Rigid machine frame
- Work bench
- Robot cell

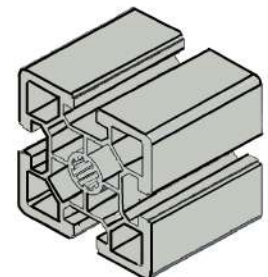
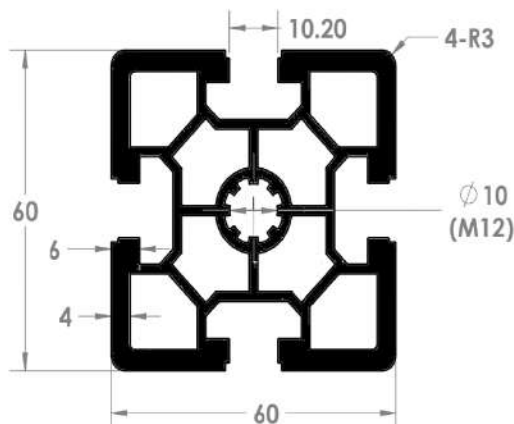

18 AUTOMATION



999 100 029

Profile 60x60-8Slot



1

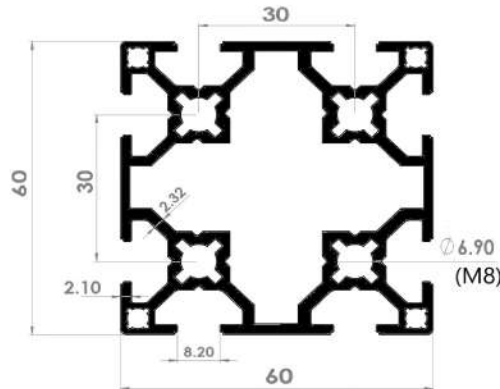

Quantity/Box	24M
Weight/M	2.44 kgs
Weight/Box	60kgs
Moment of Inertia (Ix)	39.2cm ⁴
Moment of Inertia (Iy)	39.2cm ⁴
Profile Surface	894mm ²

Application:

- Machine frames
- Work bench
- Robot cell
- Safety gaurds

999 100 044

Profile 60x120

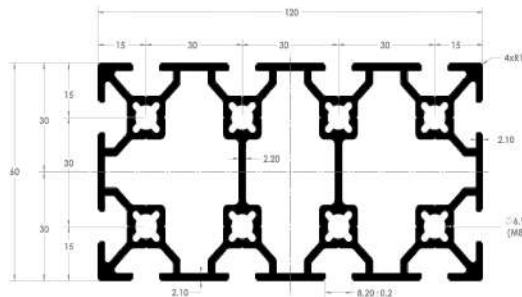
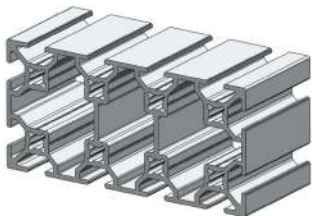

Quantity/Box	24M
Weight/M	4.6 kgs
Weight/Box	101.5 kgs
Moment of Inertia (Ix)	30 cm ⁴
Moment of Inertia (Iy)	60 cm ⁴
Profile Surface	1706.8 mm ²

Application:

- Rigid machine frame
- Heavy duty workbench
- Robot cell
- Structure base beams

999 100 030

Profile 80x80

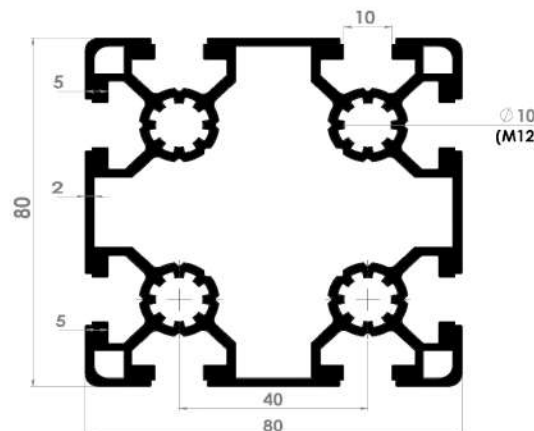

Quantity/Box	12M
Weight/M	4.22kgs
Weight/Box	76kgs
Moment of Inertia (Ix)	117cm ⁴
Moment of Inertia (Iy)	117cm ⁴
Profile Surface	1565mm ²

Application:

- Rigid machine frame
- Heavy duty workbench
- Robot cell
- Structure base beams

TELESCOPIC PROFILE

Profile 80x120



999 100 031

Quantity/Box 6M
 Weight/M 6.07kgs
 Weight/Box 75kgs
 Moment of Inertia (Ix) 389,2 cm⁴
 (Iy) 192,8 cm⁴
 Profile Surface 1970mm²

Application:

Tripods
 Laboratory Fixtures
 Structure base beams
 Workstations
 Safety gaurding

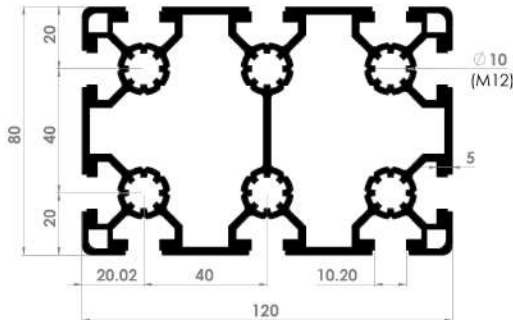

1

Profile 80x160



999 100 032

Quantity/Box 6M
 Weight/M 10kgs
 Weight/Box 60kgs
 Moment of Inertia (Ix) 850.7cm⁴
 (Iy) 253.4cm⁴
 Profile Surface 3707mm²

Application:

Workstations
 Conveyors
 Structure base beams
 Tripods
 Laboratory Fixtures

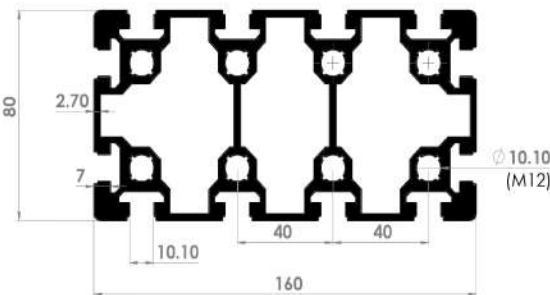

Profile 90x90



999 100 033

Quantity/Box 12M
 Weight/M 4.93kgs
 Weight/Box 90kgs
 Moment of Inertia (Ix) 195cm⁴
 (Iy) 195cm⁴
 Profile Surface 1826mm²

Application:

Rigid machine frame
 Heavy duty workbench
 Safety Gaurding
 Structure base beams
 Robot cell

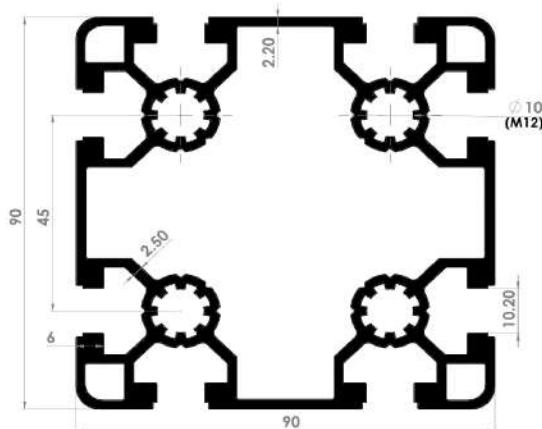

20 AUTOMATION



999 100 041

Profile 100x100

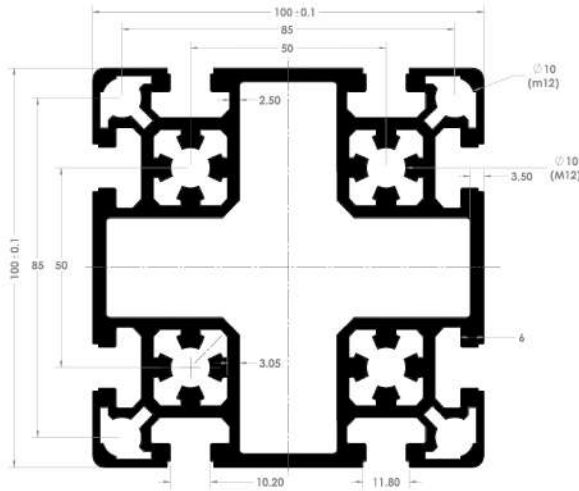

Quantity/Box	6M
Weight/M	7.98 kgs
Weight/Box	50kgs
Moment of Inertia	(Ix) 309.1cm ⁴ (Iy) 309.1cm ⁴
Profile Surface	2957.63mm ²

Application:

- Tripods
- Laboratory Fixtures
- Structure base beams
- Workstations
- Safety gaurding

PROFILE DEFLECTION

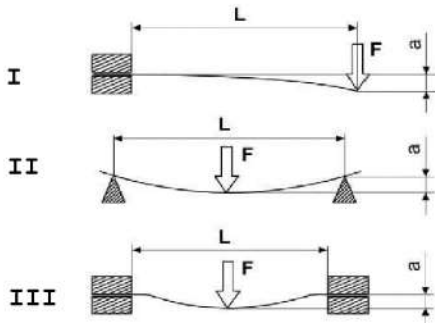

The diagram shown to the side provides a general indication of the bending of an aluminium profile. The sizing of the finished structure will be calculated on a case-by-case basis, and is the customer's responsibility.

$$a_I = \frac{F \times L^3}{3 E \times I \times 10^4}$$

Profile deflection a from force F force static stress cases I, II, III.

$$a_{II} = \frac{F \times L^3}{48 E \times I \times 10^4}$$

$$a_{III} = \frac{F \times L^3}{192 E \times I \times 10^4}$$

$$a_I = \frac{g \times m_L \times L^4}{8 E \times I \times 10^4}$$

Profile deflection a from the profiles's own weight.

$$a_{II} = \frac{5 \times g \times m_L \times L^4}{384 E \times I \times 10^4}$$

$$a_{III} = \frac{g \times m_L \times L^4}{384 E \times I \times 10^4}$$

Legend:

E = 70,000 N/mm (Modulus of Elasticity) , **F** = Load (N)

L = Unsuspended Length (mm)

a = Deflection of profile (mm)

W = Section Modulus (cm³)

m_L = Mass of Profile (Kg/mm)

I = Moment of inertia (cm⁴)

TELESCOPIC PROFILE

General

1

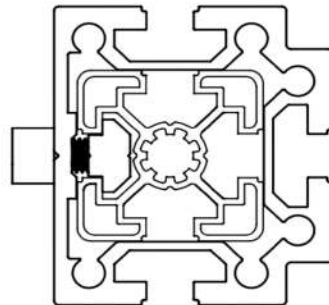

Material: Al 6063 T6
Anodized

Advantages:

Can be used to construct a height adjustable tables with Profile 40x40.

999 100 040

Telescopic Profile 40x40

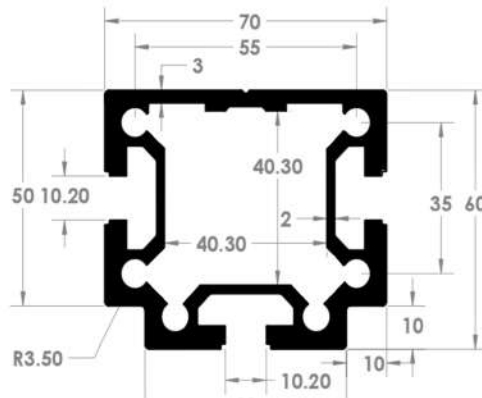

Quantity/Box : 24M
 Weight/M : 3.3Kgs
 Weight/Box : 72Kgs
 Profile Surface : 1233.50 mm²



CNC BED PROFILE

General

Material

AL 6063 T6

Application

CNC Bed Assembly

1

CNC Bed Profile 18x100

999 100 048

Quantity/Box 42M
Weight/M 1.22 kgs
Weight/Box 53kgs
Moment of Inertia (Ix) 4.5cm⁴
(Iy) 8.5cm⁴
Profile Surface 453 mm²

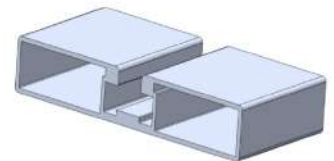
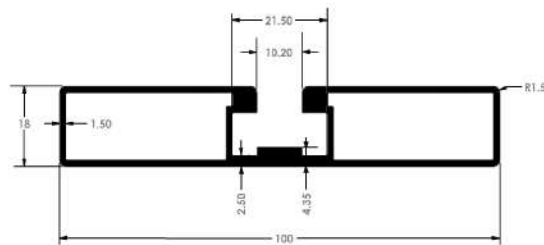



NOTES

COVER PROFILES

General

Material

PVC

Application

To cover the slots of profiles

Advantages

Protection form dirt and dust

Proper coverage of cable

Enhances the appearance of the profile structure



Cover profile		999 101...
----------------------	--	-------------------

Quantity/box 100
 Weight/pc 22g
 Weight/box 2.2kgs
 Length 3M

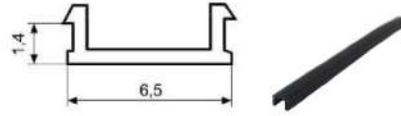

- 001 -Black (RAL 9005)
- 002 -Blue (RAL 5010)
- 003 -Gray (RAL 7035)
- 010 -Red (RAL 3020)
- 011 -Yellow (RAL 1023)
- 012 -Orange (RAL 2004)

Cover profile		999 101...
----------------------	--	-------------------

Quantity/box 100
 Weight/pc 50g
 Weight/box 5kgs
 Length 3M

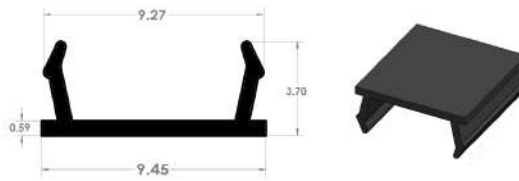

- 004 -Black (RAL 9005)
- 005 -Blue (RAL 5010)
- 006 -Gray (RAL 7035)
- 013 -Red (RAL 3020)
- 014 -Yellow (RAL 1023)
- 015 -Orange (RAL 2004)

Cover profile		999 101...
----------------------	--	-------------------

Quantity/box 100
 Weight/pc 0.117Kgs
 Weight/box 11.7Kgs
 Length 3M

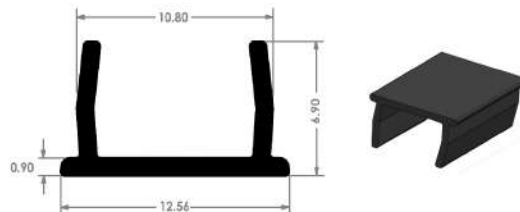

- 007 -Black (RAL 9005)
- 008 -Blue (RAL 5010)
- 009 -Gray (RAL 7035)
- 016 -Red (RAL 3020)
- 017 -Yellow (RAL 1023)
- 018 -Orange (RAL 2004)

COVER CAPS

General

1



Material

ABS (Acrylonitrile Butadiene Styrene)

Application

To cover the edges of profiles

Advantages

Protection from dirt and dust
 Proper coverage of cable
 Enhances the appearance of the profile structure

999 102...

Cover cap 20x20

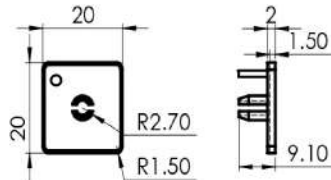

Quantity/box 1000
 Weight/pc 0.764g
 Weight/box 0.1kgs

Available colours:

Black (RAL 9005) -001
 Yellow (RAL 1023) -002
 Blue (RAL 5010) -003
 Gray (RAL 7035) -004
 Red (RAL 3020) -066
 Orange (RAL 2004) -067

999 102...

Cover cap 20x40

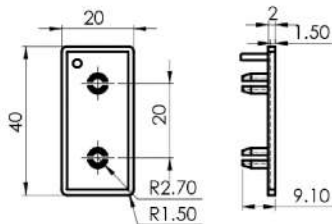

Quantity/box 200
 Weight/pc 1.49g
 Weight/box 0.2kgs

Available colours:

Black (RAL 9005) -005
 Yellow (RAL 1023) -006
 Blue (RAL 5010) -007
 Gray (RAL 7035) -008
 Red (RAL 3020) -068
 Orange (RAL 2004) -069

COVER CAPS

Cover cap 30x30

999 102...

Quantity/box 100
 Weight/pc 2g
 Weight/box 0.2kgs

Available colours:

Black (RAL 9005) -009
 Yellow (RAL 1023) -010
 Blue (RAL 5010) -011
 Gray (RAL 7035) -012
 Red (RAL 3020) -070
 Orange (RAL 2004) -071

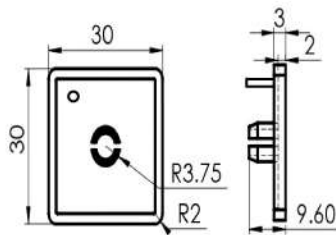

1

Cover cap 30x30 R

999 102...

Quantity/box 100
 Weight/pc 2g
 Weight/box 0.200kgs

Available colours:

Black (RAL 9005) - 013
 Yellow (RAL 1023) - 014
 Blue (RAL 5010) - 015
 Gray (RAL 7035) - 016
 Red (RAL 3020) - 072
 Orange (RAL 2004) - 073

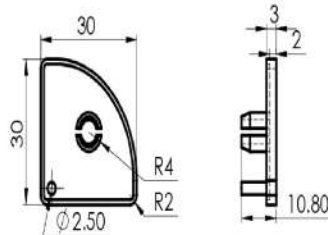

Cover cap 30x60

999 102...

Quantity/box 100
 Weight/pc 4g
 Weight/box 0.400kgs

Available colours:

Black (RAL 9005) -017
 Yellow (RAL 1023) -018
 Blue (RAL 5010) -019
 Gray (RAL 7035) -020
 Red (RAL 3020) -074
 Orange (RAL 2004) -075

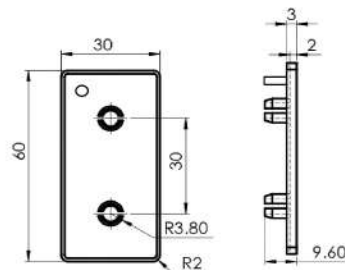

COVER CAPS

999 102...

Cover cap 40x40

1

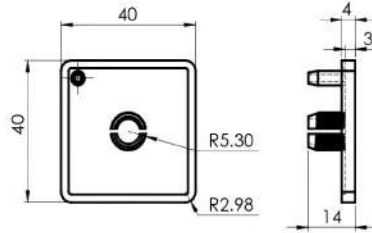

Quantity/box 100
 Weight/pc 6g
 Weight/box 0.600kgs

Available colours:

Black (RAL 9005) -021
 Yellow (RAL 1023) -022
 Blue (RAL 5010) -023
 Gray (RAL 7035) -024
 Red (RAL 3020) -076
 Orange (RAL 2004) -077

999 102...

Cover cap 40x40 R

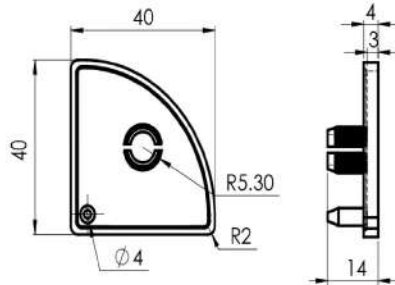

Quantity/box 100
 Weight/pc 5g
 Weight/box 0.500kgs

Available colours:

Black (RAL 9005) -026
 Yellow (RAL 1023) -027
 Blue (RAL 5010) -028
 Gray (RAL 7035) -029
 Red (RAL 3020) -078
 Orange (RAL 2004) -079

999 102...

Cover cap 40x80

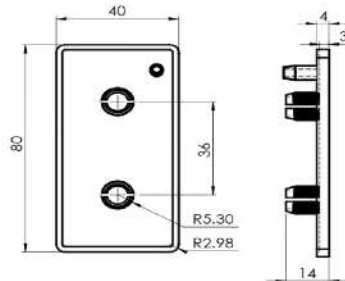

Quantity/box 100
 Weight/pc 11g
 Weight/box 1.1kgs

Available colours:

Black (RAL 9005) -030
 Yellow (RAL 1023) -031
 Blue (RAL 5010) -032
 Gray (RAL 7035) -033
 Red (RAL 3020) -080
 Orange (RAL 2004) -081

COVER CAPS

Cover cap 45x45 999 102...

Quantity/box 100
 Weight/pc 7g
 Weight/box 0.700kgs

Available colours:

- Black (RAL 9005) -034
- Yellow (RAL 1023) -035
- Blue (RAL 5010) -036
- Gray (RAL 7035) -037
- Red (RAL 3020) -082
- Orange (RAL 2004) -083

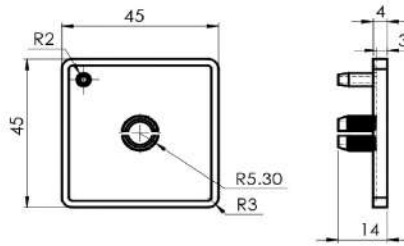

1

Cover cap 45x45 R 999 102...

Quantity/box 100
 Weight/pc 7g
 Weight/box 0.700kgs

Available colours:

- Black (RAL 9005) -038
- Yellow (RAL 1023) -039
- Blue (RAL 5010) -040
- Gray (RAL 7035) -041
- Red (RAL 3020) -084
- Orange (RAL 2004) -085

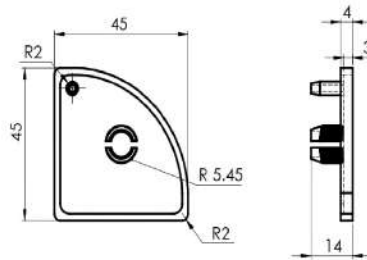

Cover cap 45x60 999 102...

Quantity/box 100
 Weight/pc 8g
 Weight/box 0.800kgs

Available colours:

- Black (RAL 9005) -042
- Yellow (RAL 1023) -043
- Blue (RAL 5010) -044
- Gray (RAL 7035) -045
- Red (RAL 3020) -086
- Orange (RAL 2004) -087

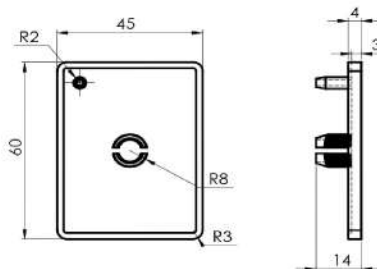

COVER CAPS

999 102...

Cover cap 45x90

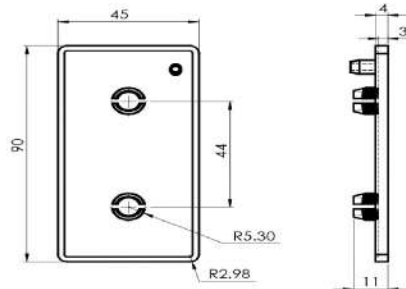

Quantity/box 100
Weight/pc 14g
Weight/box 1.4kgs

Available colours:

Black (RAL 9005) -046
Yellow (RAL 1023) -047
Blue (RAL 5010) -048
Gray (RAL 7035) -049
Red (RAL 3020) -088
Orange (RAL 2004) -089

999 102...

Cover cap 50x50

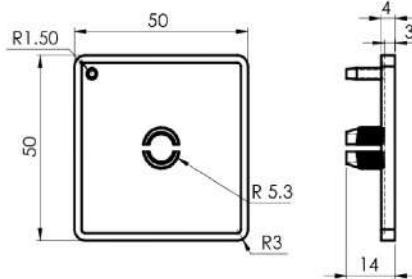

Quantity/box 100
Weight/pc 8g
Weight/box 0.800kgs

Available colours:

Black (RAL 9005) -050
Yellow (RAL 1023) -051
Blue (RAL 5010) -052
Gray (RAL 7035) -053
Red (RAL 3020) -090
Orange (RAL 2004) -091

999 102...

Cover cap 60x60

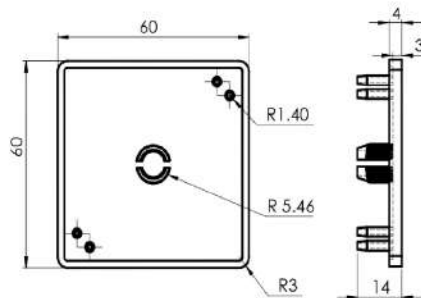

Quantity/box 100
Weight/pc 12g
Weight/box 1.20kgs

Available colours:

Black (RAL 9005) -054
Yellow (RAL 1023) -055
Blue (RAL 5010) -056
Gray (RAL 7035) -057
Red (RAL 3020) -092
Orange (RAL 2004) -093

COVER CAPS
Cover cap 80x80
999 102...

Quantity/box 100
 Weight/pc 22g
 Weight/box 2.2kgs

Available colours:

Black (RAL 9005) -058
 Yellow (RAL 1023) -059
 Blue (RAL 5010) -060
 Gray (RAL 7035) -061
 Red (RAL 3020) -094
 Orange (RAL 2004) -095

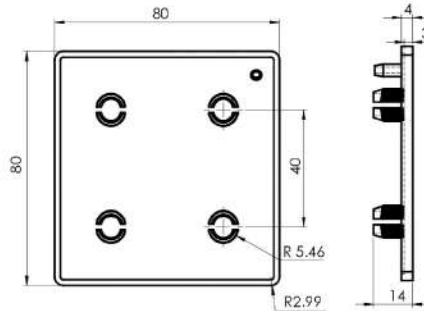
1
Cover cap 90x90
999 102...

Quantity/box 100
 Weight/pc 27g
 Weight/box 2.7kgs

Available colours:

Black (RAL 9005) -062
 Yellow (RAL 1023) -063
 Blue (RAL 5010) -064
 Gray (RAL 7035) -065
 Red (RAL 3020) -096
 Orange (RAL 2004) -097

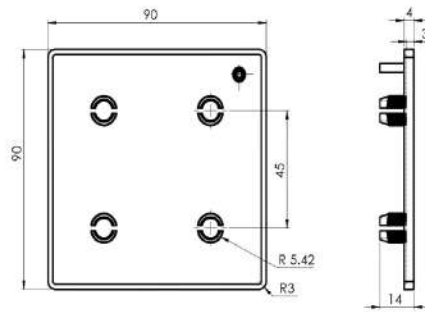

Brackets



Page : 33-36

Table Clamp
Feet bracket



Page : 37-38

Cubic Connectors
Corner Brackets
3 Way Connectors



Page : 39-43

T-Connectors
Floor Brackets



Page : 44

Central Bolts
Quick Connectors
Inner Brackets



Page : 45-48

Bolt Connector
Universal Connectors
Plates



Page : 49-53

45° Connectors
Angle Connectors
Profile Connectors
Any Degree Connectors



Page : 54-60

Fence Mount Bases



Page : 61-62

Swivel Brackets
Joints



Page : 64

Pivoting Bracket
Clamp Lever



Page : 65-68

BRACKETS

General

Material

Die cast aluminium
Surface finish (shot blasting)

Application

To connect profiles and panels rectangularly

Advantages

No tapping required, adjustable

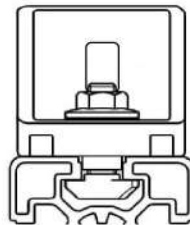

2

Bracket 20x20



999 103 001

Quantity/box	100
Weight/pc	0.004Kgs
Weight/box	0.4Kgs
Max load	700N
Bending moment	6Nm

Accessories not incl:

2xT-NUT Slot 6 M4	: 999 150 001
2x Screw M4x6	: 999 155 001
1x Cover cap	: 999 104 001

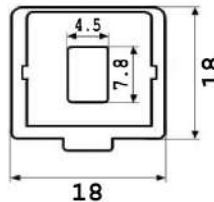

Bracket 20x40



999 103 002

Quantity/box	100
Weight/pc	0.014Kgs
Weight/box	1.4Kgs
Max load	1400N
Bending moment	12Nm

Accessories not incl:

2xT-NUT Slot 6 M4	: 999 150 001
2x Screw M4x6	: 999 155 001
1x Cover cap	: 999 104 002

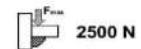
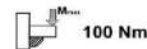
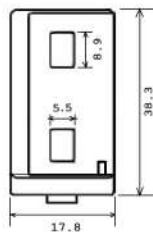

BRACKETS

999 103 003

Bracket 30x30

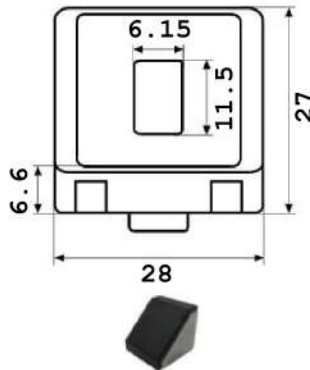

Quantity/box	500
Weight/pc	0.02kgs
Weight/box	10Kgs
Max load	1250N
Bending moment	25Nm

Accessories not incl:

2x T-Nut Slot 8 M6	: 999 150 005
2X Screw M6X12	: 999 154 002
1 Cover cap	: 999 104 003

2



999 103 004

Bracket 30x60

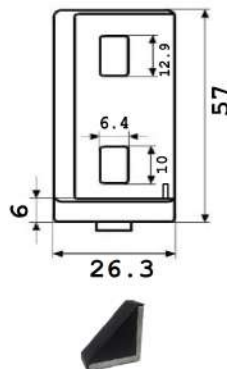

Quantity/box	400
Weight/pc	0.047Kgs
Weight/box	18.8Kgs
Max load	2500n
Bending moment	100Nm

Accessories not incl:

4x T-Nut Slot 8 M6	: 999 150 005
4x Screw M6x12	: 999 154 002
1 Cover cap	: 999 104 004



999 103 005

Bracket 40x40

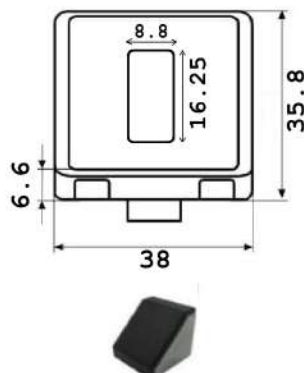

Quantity/box	250
Weight/pc	0.036Kgs
Weight/box	9Kgs
Max load	3000N
Bending moment	55Nm

Accessories not incl:

2xT-Bolt M8x20	: 999 148 002
2x Flange nut	: 999 149 001
1x Cover cap	: 999 104 005



BRACKETS

Bracket 40x40 L



999 103 016

Quantity/box 150
 Weight/pc 0.026Kgs
 Weight/box 3.9 Kgs
 Max load 2700 N
 Bending moment 40Nm

Accessories not incl:

4 x T-Bolt M8x16 : 999 154 003
 4 x Flange nut : 999 149 001

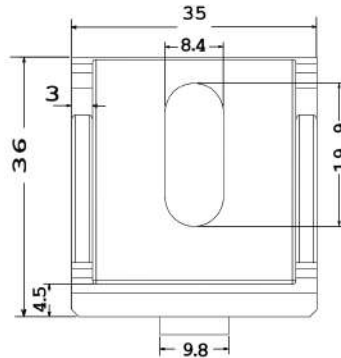

2

Bracket 40x80



999 103 006

Quantity/box 150
 Weight/pc 0.117Kgs
 Weight/box 17.55Kgs
 Max load 6000 N
 Bending moment 180Nm

Accessories not incl:

4 x T-Bolt M8x25 : 999 148 003
 4 x Flange nut : 999 149 001
 1 Cover cap : 999 104 006

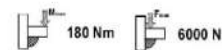
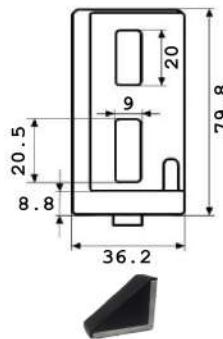

Bracket 45x45



999 103 007

Quantity/box 200
 Weight/pc 0.051Kgs
 Weight/box 10.2Kgs
 Max load 3000 N
 Bending moment 60Nm

Accessories not incl:

2 x T-Bolt M8x25 : 999 148 003
 2 x Flange nut : 999 149 001
 1 x Cover cap : 999 104 007

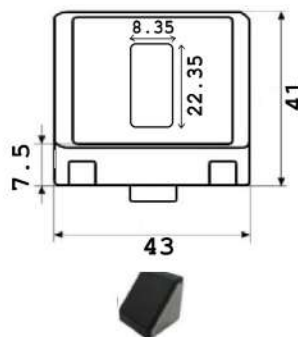

36 AUTOMATION



BRACKETS

999 103 008

Bracket 45x90

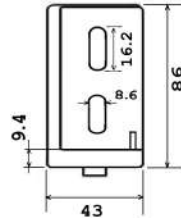

M_{max} 180 Nm F_{max} 6000 N

Quantity/box 100
 Weight/pc 0.175Kgs
 Weight/box 17.5Kgs
 Max load 6000N
 Bending moment 180Nm
 Accessories not incl:
 1 x T-Bolt M8x20 :999 148 002
 4 x Flange nut :999 149 001
 1 x Cover cap :999 104 008

999 103 009

Bracket60x60



2

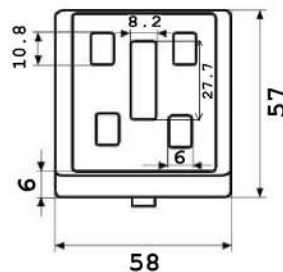

M_{max} 320 Nm F_{max} 5000 N

Quantity/box 100
 Weight/pc 0.106Kgs
 Weight/box 10.6Kgs
 Max load 3000N
 Bending moment 125Nm
 Accessories not incl:



8 x Screw M6x12 : 999 154 002
 8 x T-Nut Slot 8 M6 : 999 150 005



4 x Screw M6x12 : 999 154 002
 4 x T-Nut Slot 8 M6 : 999 150 005
 1 x T-Bolt M8x25 : 999 148 003
 1 x Flange nut : 999 149 001

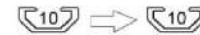

2 x T-Bolt M8x25 : 999 148 003
 2 x Flange nut : 999 149 001
 1 x Cover cap : 999 104 009

M_{max} 3000 N M_{max} 125 Nm

999 103 010

Bracket 80x80

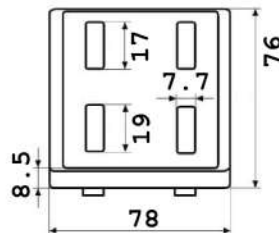

M_{max} 370 Nm F_{max} 12000 N

Quantity/box 80
 Weight/pc 0.235Kgs
 Weight/box 18.8Kgs
 Max load 12000N
 Bending moment 370Nm
 Accessories not incl:

8 x T-Bolt M8x25 : 999 148 003
 8 x Flange nut : 999 149 001
 1 x Cover cap : 999 104 010



Bracket 90x90



999 103 011

Quantity/box : 100
 Weight/pc : 0.292Kgs
 Weight/box : 29.2Kgs
 Max load : 12000N
 Bending moment : 370Nm
 Accessories not incl:
 8 x T-Bolt M8x25 : **999 148 003**
 8 x Flange nut : **999 149 001**
 1 x Cover cap : **999 104 011**

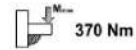
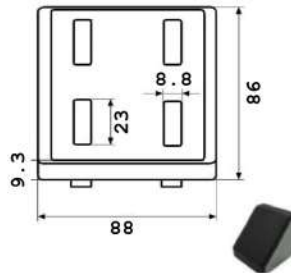

TABLE CLAMP

General

Material

Al 6063 T6

Application

To connect the table top woods with table frames.

Advantages

Rotation-proof connection, appealing design

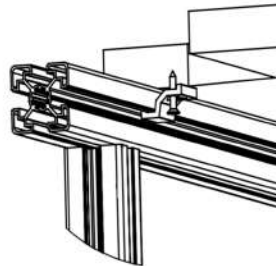

Table Top Wood Clamp

999 169 001

Quantity/box : 100
 Weight/pc : 0.011 Kgs
 Weight/box : 1.1Kgs

Accessories incl :

2XChip Board Screws Ø4x25mm

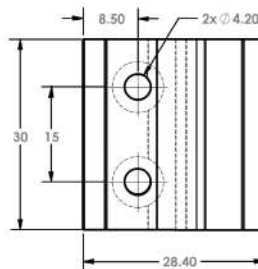
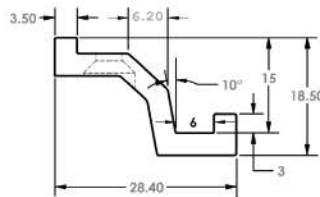

FEET BRACKET

General

Material:

Al 6063 T6

Application:

Feet Bracket for levelling feet are primarily used for securely attaching levelling Pad.

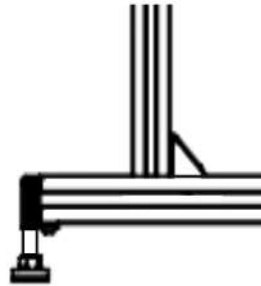

2

Feet Bracket 40x40



999 170 001

Quantity/box 10
 Weight/pc 0.097Kgs
 Weight/box 0.97Kgs

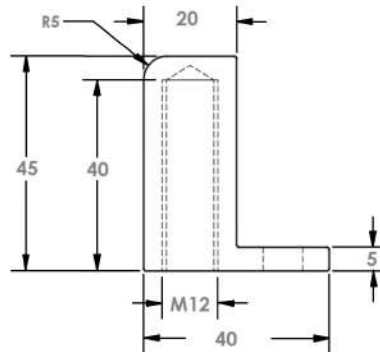

CUBIC CONNECTORS

General

Material

Die cast aluminium

Application

To connect upto three profiles rectangularly, incl. caps to cover the bores

Advantages

Rotation-proof connection, appealing design

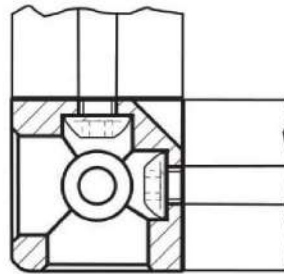
2

Cubic connector 20x20-2D

999 105 001

Quantity/box 10
 Weight/pc 10g
 Weight/box 0,1kgs
 Inclu. 2 x cover caps

Accessories not incl :

2 x central bolt M6X20 : **999 012 001**
 Cover cap Round : **999 106 001**

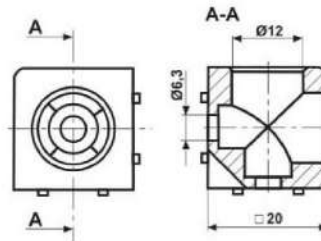

Cubic connector 20x20-3D

999 105 002

Quantity/box 10
 Weight/pc 10g
 Weight/box 0,1kgs
 Incl. 3 x cover caps

Accessories not incl

3 x Central bolt M6X20 : **999 012 001**
 Cover cap Round : **999 106 002**

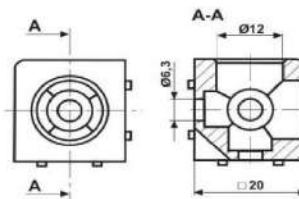

Cubic connector 30x30-2D

999 105 003

Quantity/box 10
 Weight/pc 39g
 Weight/box 0,39kgs
 Incl. 3 x cover caps

Accessories not incl

2 x Central bolt M8X20 : **999 012 002**
 Cover cap Round : **999 106 003**

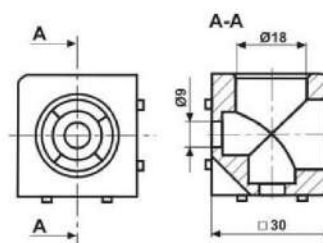

CUBIC CONNECTORS

2

999 105 004

Cubic connector 30x30-3D

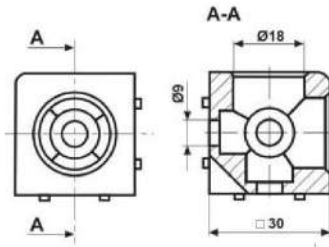

Quantity/box 10
 Weight/pc 39g
 Weight/box 0,39kgs
 Incl. 3 x cover caps
 Accessories not incl
 3 x Central bolt M8X20: **999 012 002**
 Cover cap Round : **999 106 004**

999 105 005

Cubic connector 40x40-2D

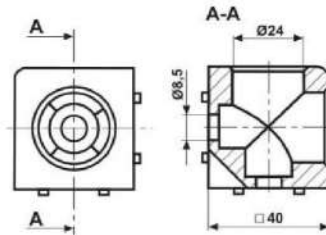

Quantity/box 10
 Weight/pc 95g
 Weight/box 0,95kgs
 Incl. 3 x cover caps
 Accessories not incl
 2 x Central bolt M12X30: **999 112 003**
 Cover cap Round : **999 106 005**

999 105 006

Cubic connector 40x40-3D

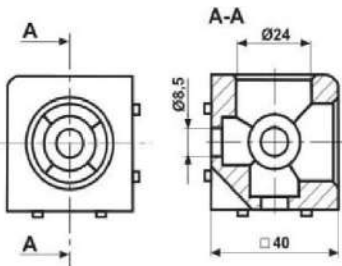

Quantity/box 10
 Weight/pc 95g
 Weight/box 0,95kgs
 Incl. 3 x cover caps
 Accessories not incl
 3 x Central bolt M12X30: **999 112 003**
 Cover cap Round : **999 106 006**

999 105 007

Cubic connector 45x45-2D

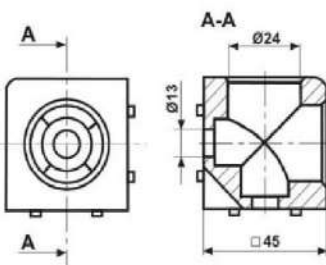

Quantity/box 10
 Weight/pc 152g
 Weight/box 1,52kgs
 Incl. 3 x cover caps
 Accessories not incl
 2 x Central bolt M12X30: **999 112 003**
 Cover cap Round : **999 106 007**

CUBIC CONNECTORS

Cubic connector 45x45-3D

999 105 008

Quantity/box 10
 Weight/pc 152g
 Weight/box 1,52kgs

Incl. 3 x cover caps

Accessories not incl
 3 x Central bolt M12X30: **999 112 003**
 Cover cap Round : **999 106 008**

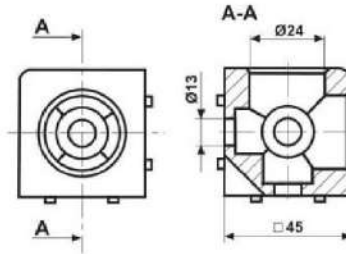

2

CORNER BRACKETS

General

Material

Die cast aluminium

Application

To connect three profiles
 rectangularly

Advantages

Rotation-proof connection,
 appealing design



Coner bracket 20x20

999 107 001

Quantity/box 10
 Weight/pc 10g
 Weight/box 0,1kgs

Accessories not incl:
 3 x Countersunk
 screw M5x20: **999 155 003**

1 x Cover cap round : **999 108 001**

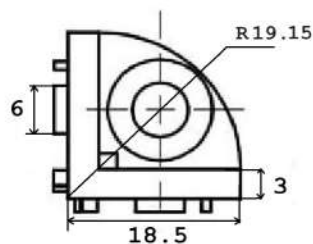

M_{max}
22 Nm

Corner bracket 30x30

999 107 002

Quantity/box 10
 Weight/pc 40g
 Weight/box 0,4kgs

Accessories not incl:
 3 x Countersunk
 screw M8x25 : **999 155 004**

1 x Cover cap round : **999 108 002**

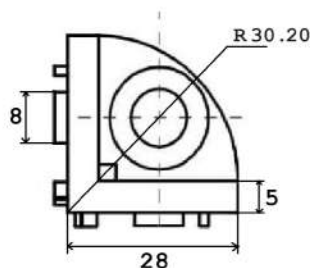

M_{max}
85 Nm

CORNER BRACKETS

999 107 003

Corner bracket 40x40

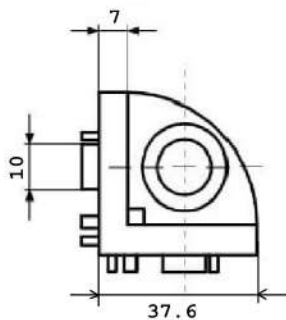

Quantity/box	10
Weight/pc	85g
Weight/box	0,85kgs

Accessories not incl:

3 x Countersunk screw M8x30	: 999 155 005
1 x Cover cap round	: 999 108 003
3 x Reducer M12toM8	: 999 162 001

999 107 004

Corner bracket 45x45

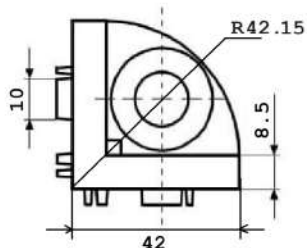

Quantity/box	10
Weight/pc	132g
Weight/box	1,32kgs

Accessories not incl:

3 x Countersunk screw M8x30	: 999 155 005
1 x Cover cap round	: 999 108 004
3 x Reducer M12toM8	: 999 162 001

3 WAY CONNECTROS

General

Material

Die cast aluminium

Application

3D mounting of aluminum profiles

Advantages

Extremely light, stable, resilient



3 Way connetor 20x20



999 109 001

Quantity/box
Weight/pc
Weight/box

25
21g
0.52kgs

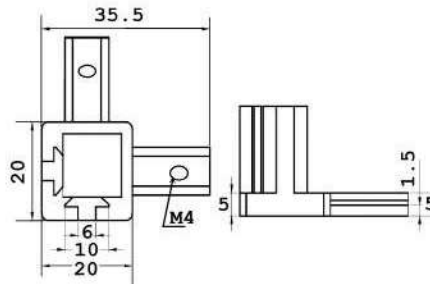

3 Way connector 30x30



999 109 002

Quantity/box
Weight/pc
Weight/box

25
63g
1.57kgs

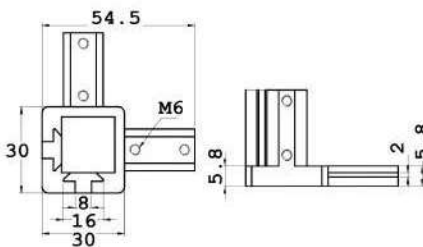

3 Way connector 40x40



999 109 003

Quantity/box
Weight/pc
Weight/box

25
156g
3.90kgs

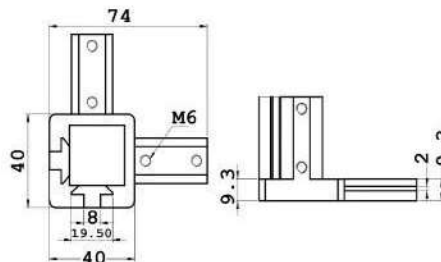

T CONNECTOR

General

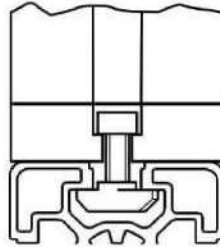

Material

Die cast zinc for prfoile 45x45

Application

To connect profile 45x45 rectangularly to other profiles or plates

Advantages

High strength connection, appealing design

999 110 ...

T Connector



30X30 : 001
40X40 : 002
45X45 : 003

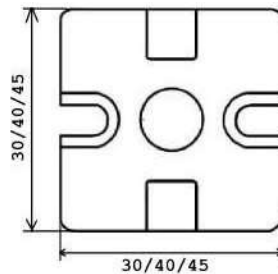

Quantity/box	100
Weight/pc	55g
Weight/box	5,5kgs
Height	13mm
Max load	9000N
Bending moment	200Nm
Accessories not incl:	
1 x Central Bolt M12X30	
2 X t-Nut Slot 10 M6	
2 X Screws M6X16	

FLOOR BRACKET

General

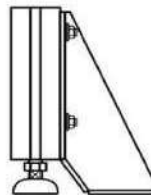

Material

Zinc plated steel 4mm thickness for screws Ø 8mm

Application

To securely fix aluminium profiles to the floor to prevent any movement of the structure

999 111 001

Floor bracket

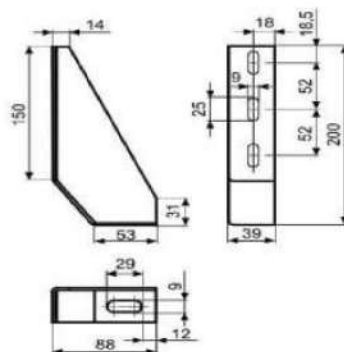

Quantity/box	10
Weight/pc	0.572Kgs
Weight/box	5,5kgs
Accessories not incl:	
2 x T-Bolt M8X25	: 999 148 003
2 x Flange nut	: 999 149 001

CENTRAL BOLT

General

Material

Steel, Zinc plated

Application

To connect profiles rectangularly

Advantages

Not visible, low cost

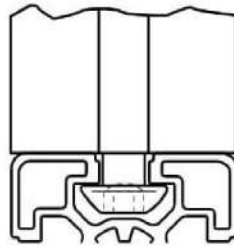

Central bolt 999 112 ...

M8X20



Quantity/box 200
Weight/pc 10g
Weight/box 2,0kgs

M12X30



Quantity/box 250
Weight/pc 29g
Weight/box 2,9kgs

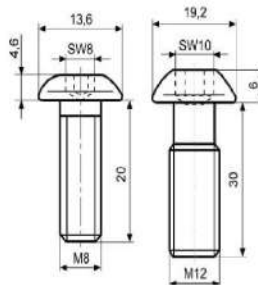

M6x20:001



M12x30:003



M8x20:002



M6X12:004



M8X16: 005

M4X8 : 006

M5X8 : 007

Thread Forming central bolt 999 113 ...

S8x25



Quantity/box 100
Weight/pc 11g
Weight/box 1,1kgs

S12x30



Quantity/box 100
Weight/pc 25g
Weight/box 2,5kgs

S8: 001



⊛ T40

S12: 002



⊛ T50

QUICK CONNECTORS

General

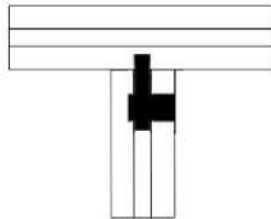

Material

Steel, Zinc Plated

Application

To make solid, rectangular connection of two profiles.

Advantages

High tensile strength, easy to insert panels

2

999 114 ...



Quick Connector



0°:001

90°:002

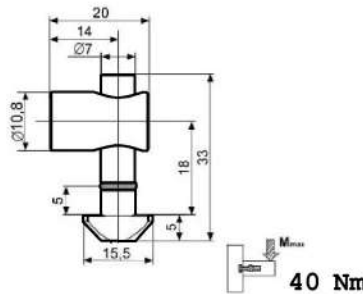

Quantity/box	100
Weight/Pc	20g
Weight/box	2.0kgs

Drilling (Ø)	11mm
Distance to the end profile	18mm
Depth 30x30	22mm

999 114 ...



Quick Connector



0°:003

90°:004

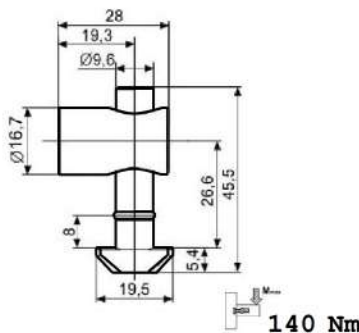

Quantity/box	100
Weight/Pc	55g
Weight/box	5.5kgs

Drilling (Ø)	17mm
Distance to the end profile	22.5mm
Depth 40x40	31mm
Depth 45x45	34mm

QUICK CONNECTORS

Quick Connector



12Nm

999 114 ...

Quantity/box 100
 Weight/Pc 0.026kgs
 Weight/box 2.6Kgs
 Drilling (Ø) 11mm
 Distance to the end profile 18mm
 Depth 30x30 22mm

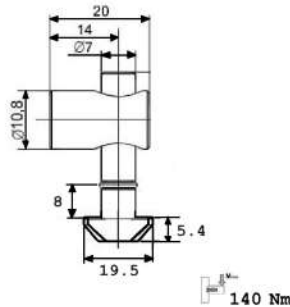

0°: 005 90°: 006



2

Any Degree Quick Connector



999 114 ...

Quantity/box 100
 Weight/Pc 0.045Kgs
 Weight/box 4.5Kgs
 Drilling (Ø) 17mm
 Distance to the end profile 22.5mm
 Depth 40x40 31mm
 Depth 45x45 34mm

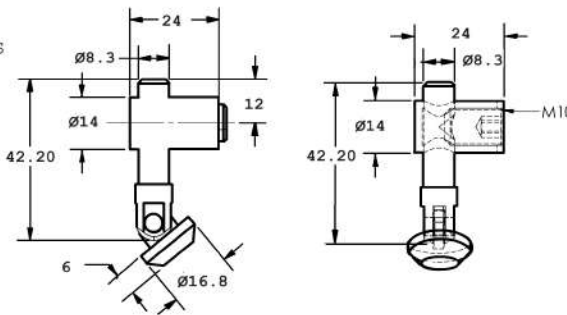

0°: 007 90°: 008



INNER BRACKETS

General

Material

Die-cast zinc,
 Surface: Nickel plated

Application

Frames, Light shelves,
 displays

Advantages

No machining or drilling
 required, easy mounting

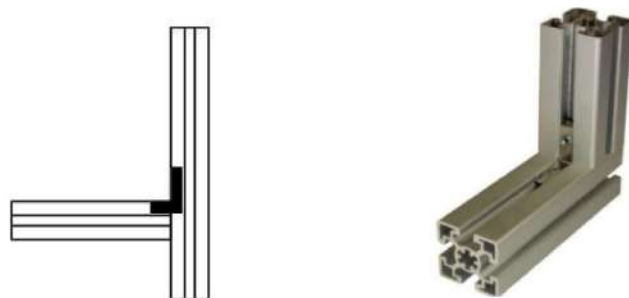

140 Nm

48 AUTOMATION



INNER BRACKET

999 115 001

Inner bracket

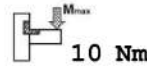
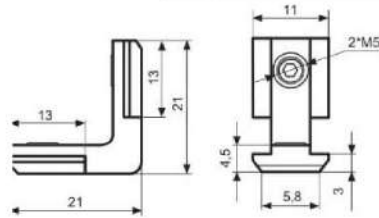

Quantity/box 100
Weight/pc 9g
Weight/box 0.90kgs
Including Screws

999 115 002

Inner bracket (A)

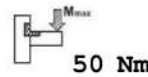
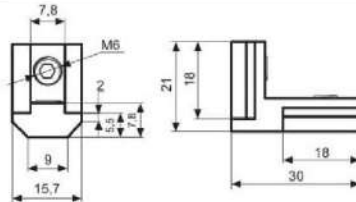

Quantity/box 100
Weight/pc 24g
Weight/box 2.4kgs
Including Screws

999 115 003

Inner bracket (B)

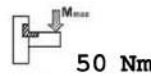
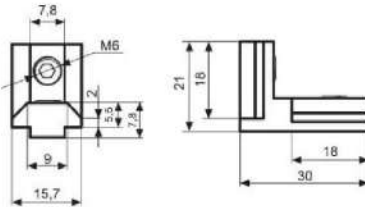

Quantity/box 100
Weight/pc 24g
Weight/box 2.4kgs
Including Screws

999 115 004

Inner bracket (A)

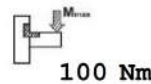
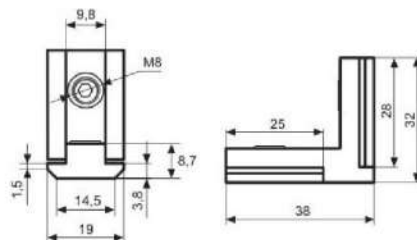

Quantity/box 100
Weight/pc 44g
Weight/box 4.2kgs
Including Screws

999 115 005

Inner bracket (B)

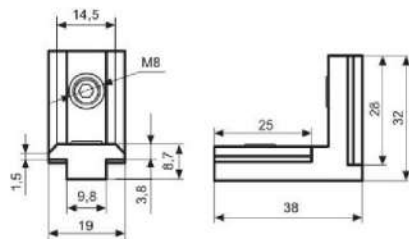

Quantity/box 100
Weight/pc 44g
Weight/box 4.2kgs
Including Screws

BOLT CONNETORS

General

Base element: Zinc plated steel
 Screws: Zinc plated steel
 Hammer nut: Zinc plated steel
 Fixing bolts: Nylon PA, Glass fibre reinforced
 Screw covers: Nylon PA, Glass fibre reinforced

Application

To connect two aluminium profiles regularly

Advantages

Suitable for heavy loads and torsional stress



2

Bolt connector set

999 116 ...

Quantity/box 10
 Weight/set Refer table
 Weight/box Refer table

Including screws and T Nuts

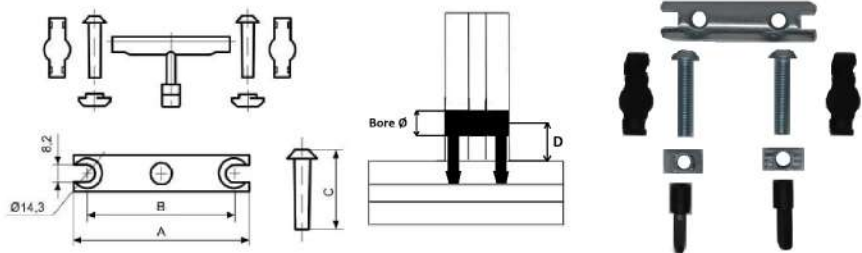

Profile Type	Order Code 999 116...			Bore \varnothing	Screw		Weight/ set	Weight/ Box	A	B	C	D
30X30	001	2500N	60Nm	8.2mm	M5	6Nm	26g	0,26kgs	28mm	18mm	25mm	22,5mm
40X40	002	4000N	180Nm	17mm	M8	25Nm	74g	0,74kgs	37mm	23mm	35mm	22,5mm
45X45	003	4000N	190Nm	17mm	M8	25Nm	78g	0,78kgs	42mm	28mm	35mm	22,5mm
60X60	004	4000N	200Nm	17mm	M8	25Nm	83g	0,83kgs	57mm	43mm	35mm	22,5mm
80X80	005	5000N	800Nm	17mm	M8	25Nm	121g	1,21kgs	77mm	63mm	35mm	22,5mm
90X90	006	5000N	800Nm	17mm	M8	25Nm	133g	1,33kgs	87mm	73mm	35mm	22,5mm

UNIVERSAL CONNECTORS

General



Material

Die cast aluminium

Application

To connect two aluminium profiles rectangularly

Advantages

Suitable for heavy loads and torsional stress

2

999 117 001

Universal Connector

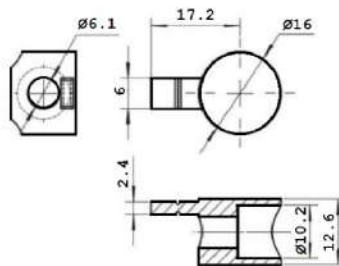
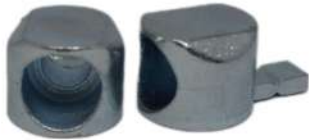

Quantity/box

50

Weight/pc

10g

Weight/box

0.50kgs

999 117 002

Universal Connector

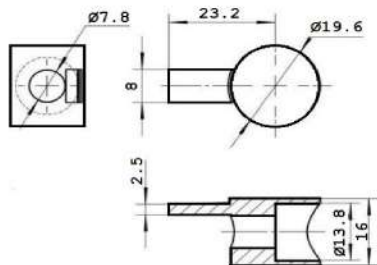

Quantity/box

50

Weight/pc

18g

Weight/box

0.90kgs

PLATES

Material

Steel, Zinc Plated

Application

To connect profile 45x45
rectangularly to other
profiles or plates

Advantages

High strength connection,
appealing design



2

Straight Joint (- Type)

999 118 001

Quantity/box 10
Weight/pc 65g
Weight/box 0.65kgs

Accessories not included

Suitable for M6 Screw

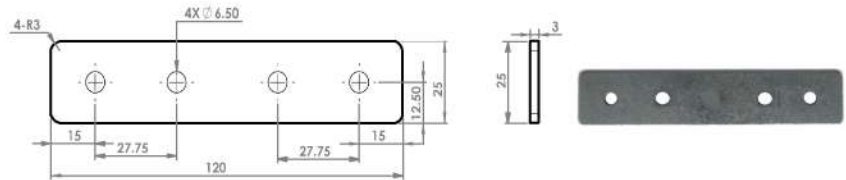

4 Way Joint (+ Type)

999 118 002

Quantity/box 10
Weight/pc 118g
Weight/box 1.18kgs

Accessories not included

Suitable for M6 Screw

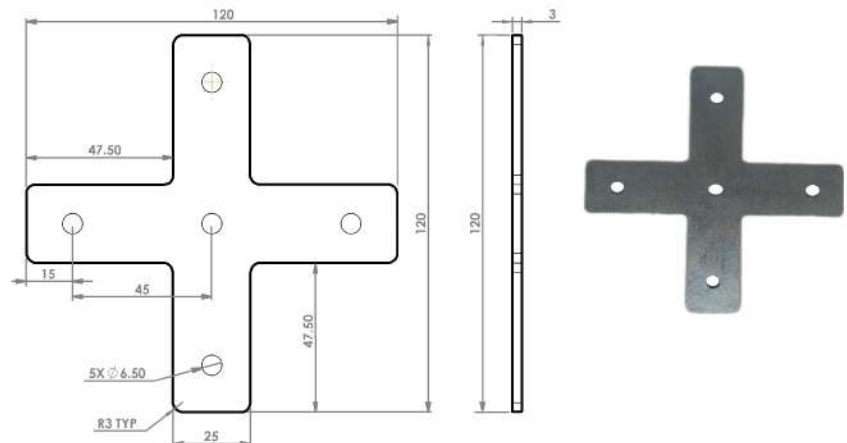

PLATES

999 118 003

2 Way Joint (L Type)

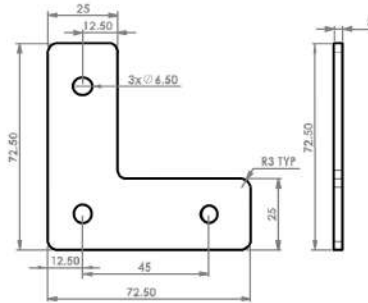

Quantity/box 10
Weight/pc 66g
Weight/box 0.66kgs

Accessories not included
Suitable for M6 Screw

2

999 118 004

3 Way Joint (T Type)

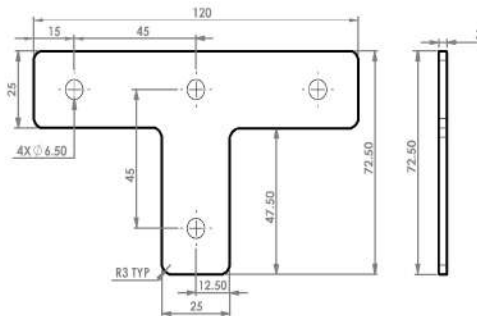

Quantity/box 10
Weight/pc 91g
Weight/box 0.90kgs

Accessories not included
Suitable for M6 Screw

999 118 005

Straight Joint (- Type)

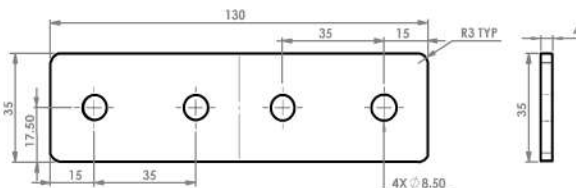

Quantity/box 10
Weight/pc 132g
Weight/box 1.32kgs

Accessories not included
Suitable for M8 Screw

PLATES

4 Way Joint (+ Type)

999 118 006

Quantity/box 10
 Weight/pc 236g
 Weight/box 2.36kgs

Accessories not included

Suitable for M8 Screw

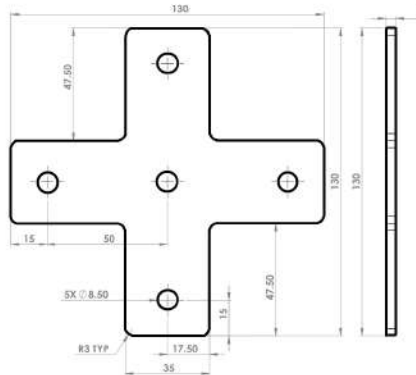

2 Way Joint (L Type)

999 118 007

Quantity/box 10
 Weight/pc 136g
 Weight/box 1.36kgs

Accessories not included

Suitable for M8 Screw

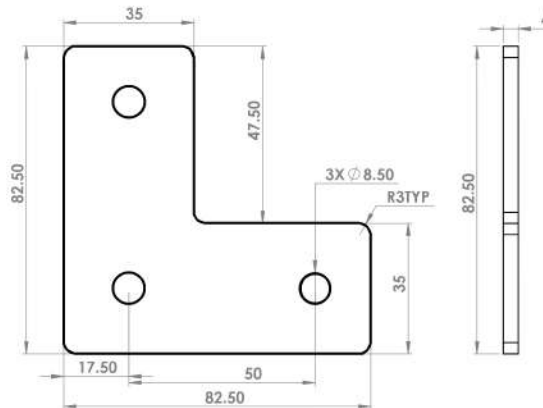

3 Way Joint (T Type)

999 118 008

Quantity/box 10
 Weight/pc 185g
 Weight/box 1.85kgs

Accessories not included

Suitable for M8 Screw

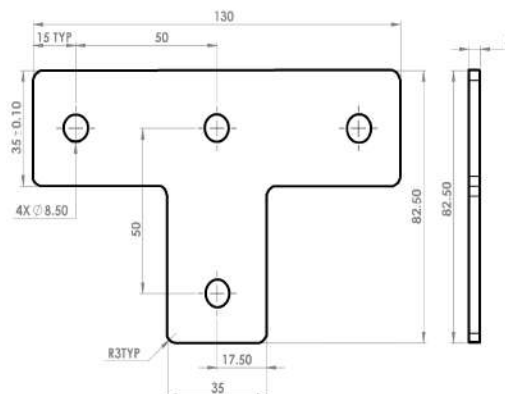

45° CONNECTORS

General

Material

Die cast aluminium
plain surface
Cover cap : PA,black

Application

To connect profiles
under 45°

Advantages

make structures
more rigid



999 119 001

45° connector 30



Quantity/box 5
Weight/PC 45g
Weight/box 0,225kgs

1 x Cover cap incl

Accessories not incl:
2 x Screw M8, : 999 154 003
Nut (s)

2

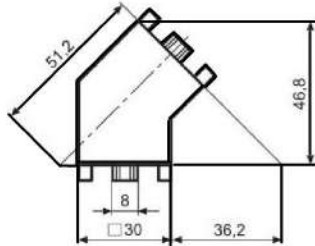

999 119 002

45° Connector 40



Quantity/box 2
Weight/Set 250g
Weight/box 0,500kgs

1 x Cover cap incl

Accessories incl:

1 x T-Bolt M8x20 : 999 148 002
1 x Flange nut M8 : 999 149 001
2 x Bolt 12X30 : 999 112 003

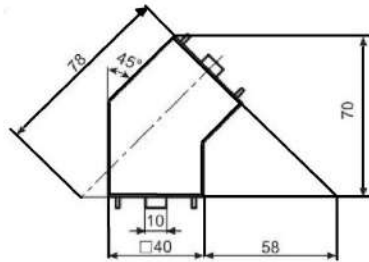

999 119 003

45° Connector 45



Quantity/box 5
Weight/Set 155g
Weight/box 0,775kgs

1 x Cover cap incl.

Accessories not incl.

2 x Screw M12 : 999 154 005
Nut (s)

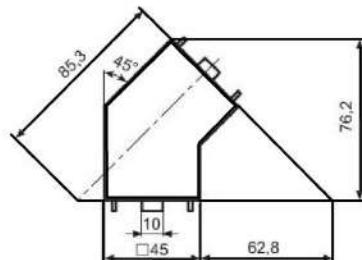

45° PROFILE CUTTING CONNECTOR

45° Profile cutting connector 30x30

999 120 001

Quantity/box 10
 Weight/pc 31g
 Weight/box 0.31kgs

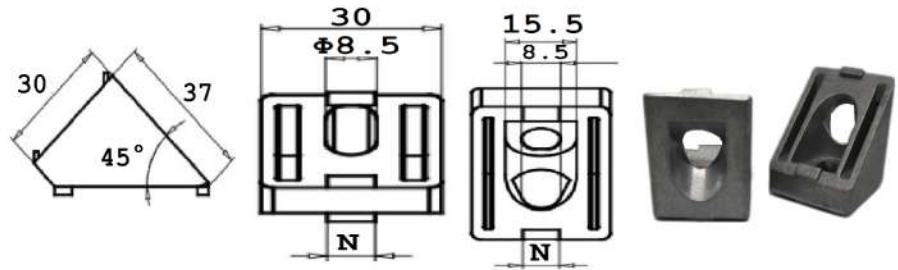

ANGLE CONNECTORS

General

Material

Die cast aluminium
 plain surface
 Cover cap : PA,black

Application

To connect profiles
 under 45°

Advantages

make structures
 more rigid



Angle connector 45° 30x30

999 121 003

Quantity/box 10
 Weight/pc 0.045kgs
 Weight/box 0.45kgs

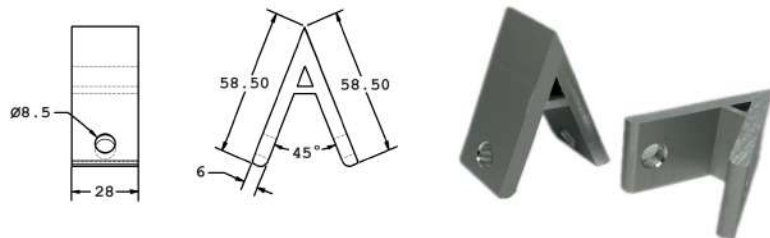

Angle connector 135° 30x30

999 121 004

Quantity/box 10
 Weight/pc 0.048kgs
 Weight/box 0.48kgs

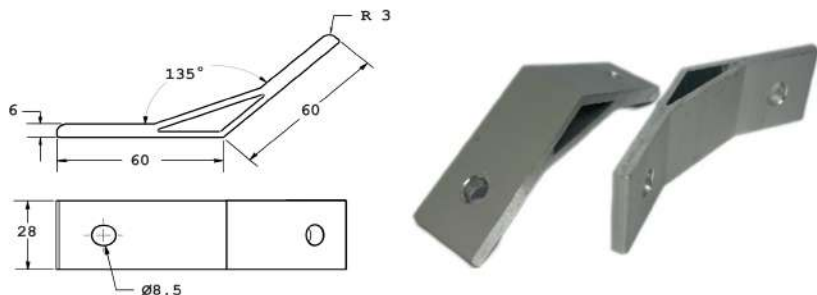

Angle connector 45°, 40X40

999 121 001

Quantity/box 10
Weight/pc 52g
Weight/box 0.52kgs

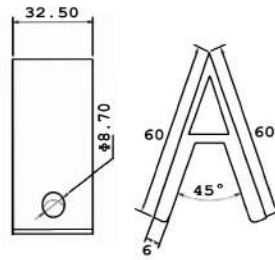

2

Angle connector 135°, 40X40

999 121 002

Quantity/box 10
Weight/pc 54g
Weight/box 0.54kgs

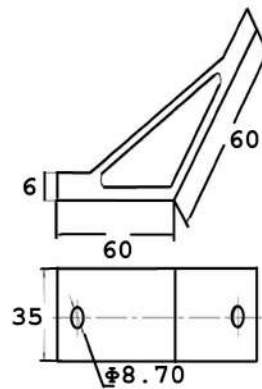

PROFILE CONNECTOR

General

Material

Steel, Zinc plated

Application

make connections for profile end to end

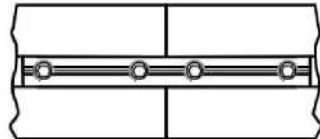

Profile connector

999 122 001

Quantity/box 50
Weight/pc 21g
Weight/box 1.05kgs

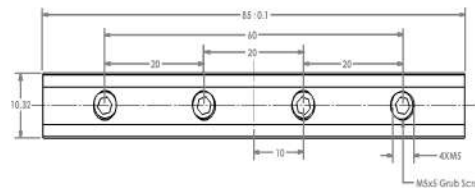
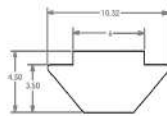

4 x headless screw
M5X5

Profile connector 180mm

999 122 002

Quantity/box 25
Weight/pc 0.1kgs
Weight/box 2.5kgs

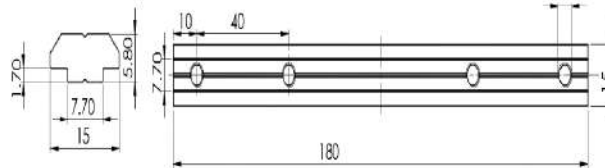

Included in delivery:

4 x headless screw
M6X6

Profile connector 140mm

999 122 008

Quantity/box 25
Weight/pc 0.084kgs
Weight/box 2.1kgs

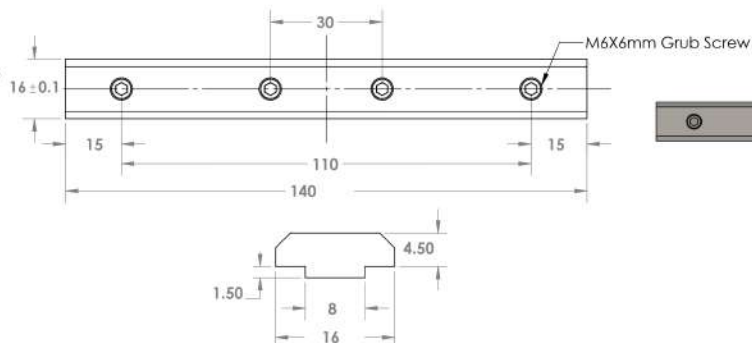

Included in delivery:

4 x headless screw
M6X6

PROFILE CONNECTOR

999 122 009

Profile connector 100mm

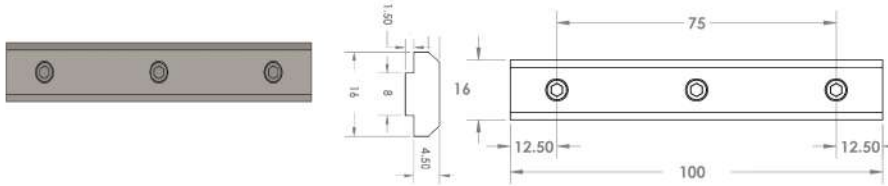

Quantity/box 25
 Weight/pc 0.060kgs
 Weight/box 1.5kgs

Included in delivery:

3 x headless screw
 M6X6

999 122 010

Profile connector 80mm

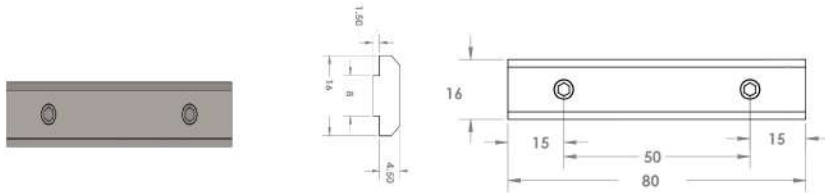

Quantity/box 25
 Weight/pc 0.048kgs
 Weight/box 1.2kgs

Included in delivery:

2 x headless screw
 M6X6

2

999 122 011

Profile connector 40mm

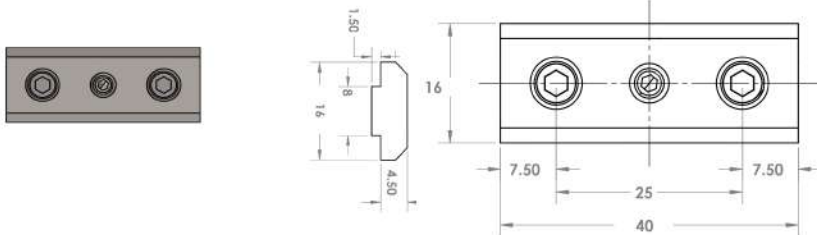

Quantity/box 25
 Weight/pc 0.022kgs
 Weight/box 0.55kgs

Included in delivery:

2 x headless screw
 M6x6
 1 x headless screw
 M4x6

999 122 003

Profile connector 180mm

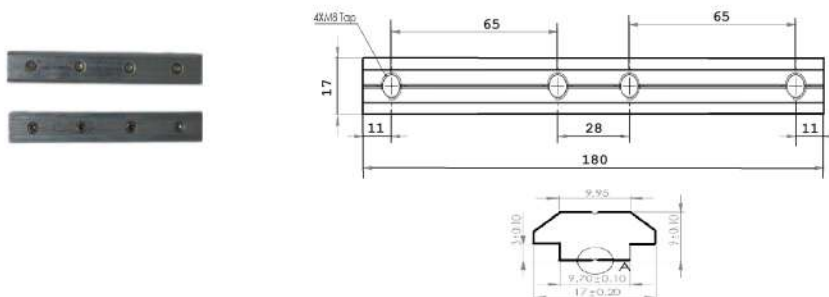

Quantity/box 25
 Weight/pc 0.157kgs
 Weight/box 3.925kgs

Included in delivery:

4 x headless screw
 M8x10

PROFILE CONNECTOR

Profile connector 140mm
999 122 004

Quantity/box 25
 Weight/pc 0.125kgs
 Weight/box 3.125kgs

Included in delivery:

4 x headless screw
 M8x10

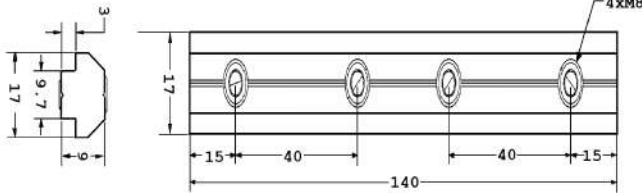
Profile connector 100mm
999 122 005

Quantity/box 25
 Weight/pc 0.089kgs
 Weight/box 2.225kgs

Included in delivery:

4 x headless screw
 M8x10

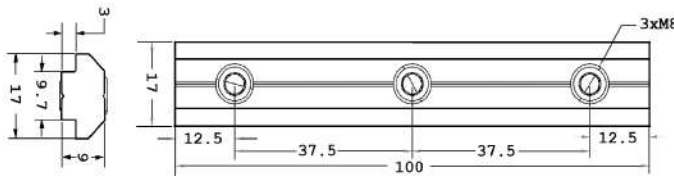
Profile connector 80mm
999 122 006

Quantity/box 25
 Weight/pc 0.072kgs
 Weight/box 1.8kgs

Included in delivery:

4 x headless screw
 M8x10

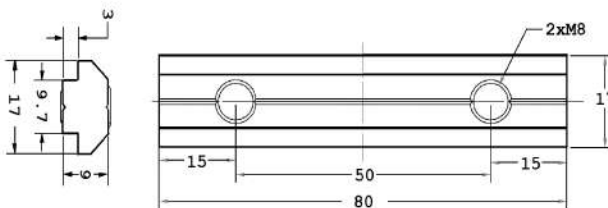
Profile connector 40mm
999 122 007

Quantity/box 25
 Weight/pc 0.036kgs
 Weight/box 0.9kgs

Included in delivery:

4 x headless screw
 M8x10

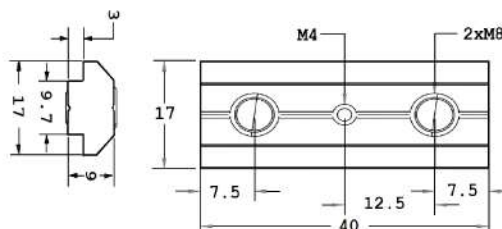

ANY DEGREE CONNECTORS

General



Material

Steel, Zinc plated

Application

make connections for profile end to end

2

999 123 001

Any degree connector outer small

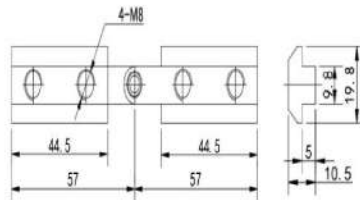

Quantity/box	10
Weight/pc	107g
Weight/box	1.07kgs

999 123 002

Any degree connector inner long

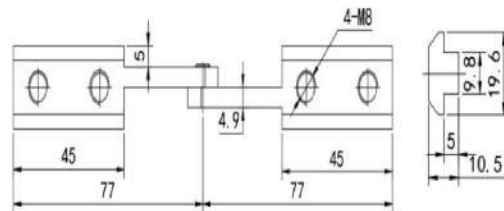

Quantity/box	10
Weight/pc	123g
Weight/box	1.23kgs



FENCE MOUNT BASE

General

Material

Die cast aluminium

Application

To mount profile pillars to the floor

Advantages

Aligning feature,
appealing design



Fence Mount Base 40

999 124 ...

2

Quantity/box : 1
Weight/pc : 0.847Kgs
Weight/box : 0.847Kgs

Accessories not included

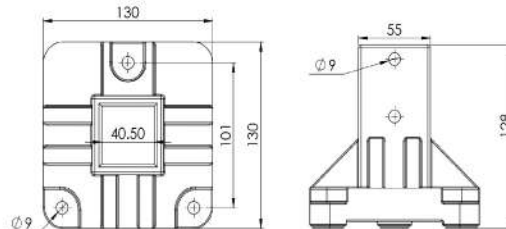

Black: 001



Gray : 004

Fence Mount Base 45

999 124 002

Quantity/box : 1
Weight/pc : 0.558Kgs
Weight/box : 0.558Kgs

Accessories not included

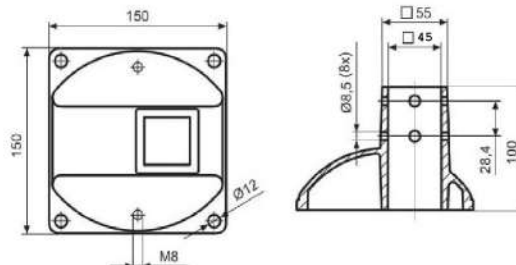

FENCE MOUNT BASE

999 124 003

Fence Mount Base 60x60

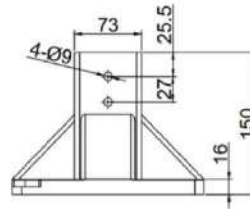
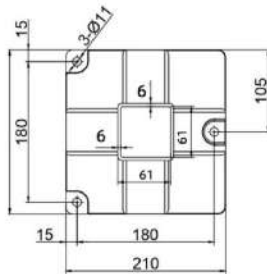

Quantity/box : 1
 Weight/pc : 1.452Kgs
 Weight/box : 1.452Kgs

Accessories not included

2

999 124 005

Fence Mount Base 80x80

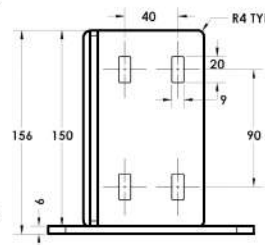
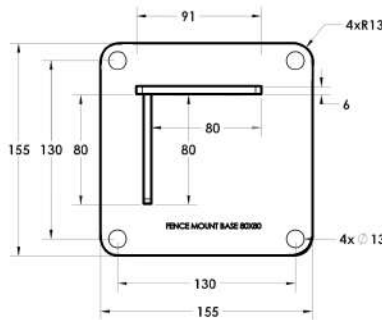

Quantity/box : 1
 Weight/pc : 2.37Kgs
 Weight/box : 2.37Kgs

Material:
 Steel, Zinc plated

Accessories not included

Profile Type	Model Type	Order Code	Weight/Pc	Weight/Box
40x40	40x40 (Black)	999 124 001	0.847Kgs	0.847Kgs
40x40	40x40 (Gray)	999 124 004	0.847Kgs	0.847Kgs
45x45	45x45 (Black)	999 124 002	0.558Kgs	0.558Kgs
60x60	60x60 (Gray)	999 124 003	1.452Kgs	1.452Kgs
80x80	80x80	999 124 005	2.37Kgs	2.37Kgs



NOTES

SWIVEL BRACKETS

General

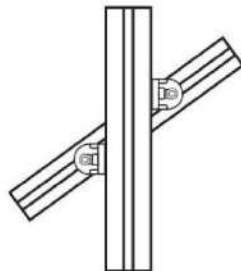

Material
Aluminium Die cast

Application
To connect profiles at an adjustable

Advantages
No machining required

2

999 125 001 Swivel bracket 28x38R

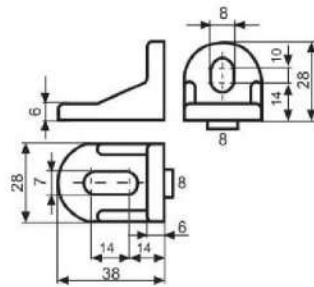

Quantity/box	10
Weight/pc	16g
Weight/box	0,16kgs

999 125 002 Swivel bracket 40x43R

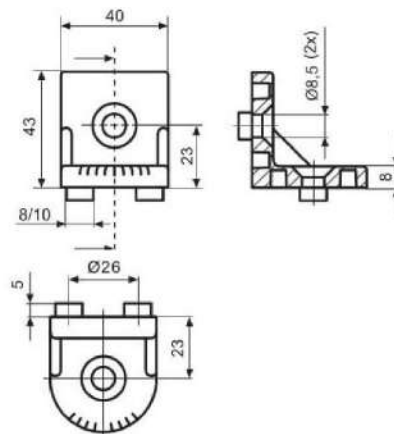

Quantity/box	10
Weight/pc	45g
Weight/box	0,45kgs

PIVOT JOINTS

General

Material

Joint: Die-cast zinc
 Locking lever: Nylon PA,
 glass filled reinforced

Application

To make a pivoting connection
 between 2 profiles or panels which
 can be fixed at any angle; fixed
 locating pins for slot 8 or 10 optional

Advantages

By tightening or loosening the screw
 and the locking lever seamlessly regulate
 the functionality of the joint or you
 can fix it in one position



Pivot joint 20



999 126 ...

Quantity/box 2
 Weight/pc 0.036kgs
 Weight/box 0.072kgs

Available

without lever : 999 126 010

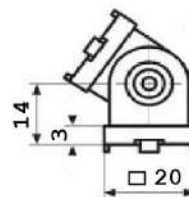

Pivot joint 30



999 126 ...

Quantity/box 2
 Weight/pc 160g
 Weight/box 0,32kgs

Available

with lever : 999 126 001

without lever : 999 126 002

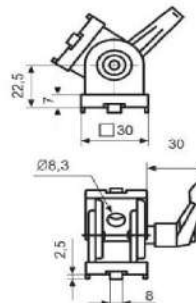

999 126 ...

Pivot joint



Pivot joint 40

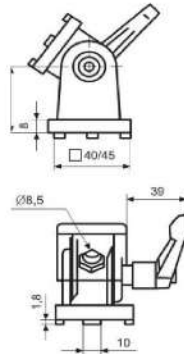

Quantity/box	2
Weight/pc	340/390g
Weight/box	0,68/0,78kgs

Also Available:

Pivot joint 40 with lever	: 999 126 003
without lever	: 999 126 004

Pivot joint 45 with lever	: 999 126 005
without lever	: 999 126 006

Pivot joint 45



2

999 126 007

Pivot Joint 40x80

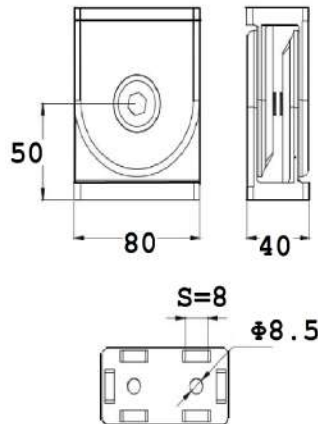

Quantity/box	2
Weight/pc	1.03kgs
Weight/box	2.06kgs

Available
without lever

Pivot Joint 50x50

999 126 008

Quantity/box 2
 Weight/pc 0.43kgs
 Weight/box 0.86kgs

Available
 without lever

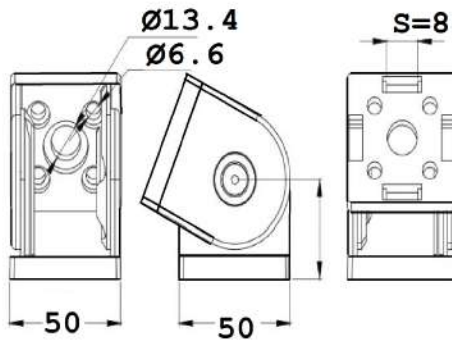

Pivot Joint 80x80

999 126 009

Quantity/box 2
 Weight/pc 1.40kgs
 Weight/box 2.8kgs

Available
 without lever

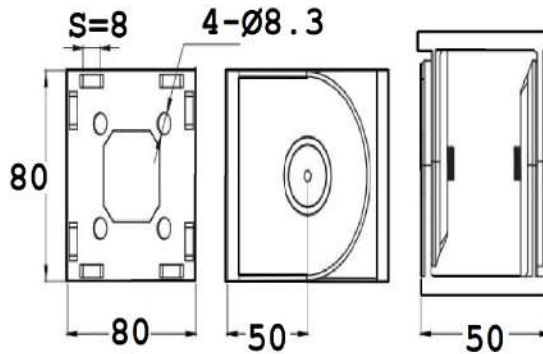

PIVOTING BRACKET

General



Material

Steel, zinc plated

Application

Adjustable angle connector, lockable

2

999 127 001

Pivoting bracket

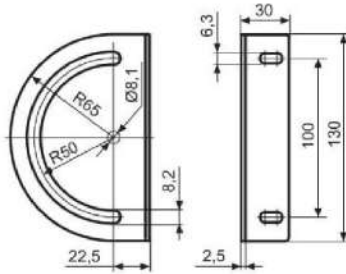

Quantity/box	10
Weight/pc	220g
Weight/box	2,2kgs

Accessories not incl.

CLAMP LEVER

999 128...

Clamp Lever



M8x16: 001



M8x20: 002

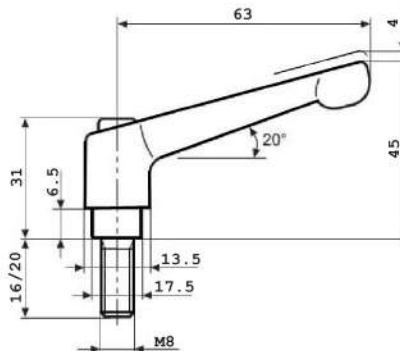

Material

Plastic, glass fibre reinforced steel, zinc plated

M8x16: 001

Quantity/box	10
Weight/pc	0.036kgs
Weight/box	0.36kgs

M8x20: 001

Quantity/box	10
Weight/pc	0.038kgs
Weight/box	0.38kgs

Note:

For Slot-8 kindly use washers due to thread length.

Feet



Page: 70-72

Castors

Castors (FOOT MASTER)



Page: 73-75

**Transport and
Base Plates**



Page: 76

FEET

General



Application

Foot to compensate uneven floor and for height adjustment

999 129...

Feet Polyamide



Ø30:001

Ø60:006
(M8)

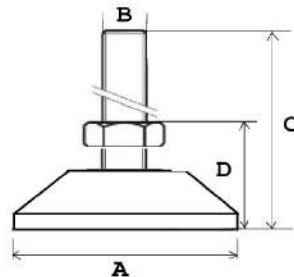

Quantity/box 10

Swivelling range +/-5°

Includes locking nut M8 or M12

Ø60:002
(M12)

Ø80:003



Ø100:004

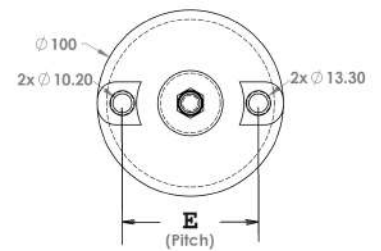
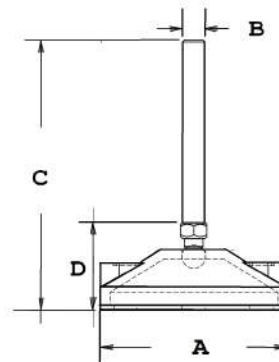

Ø100:004

Ø40:005



Order Code 999 129..	A	B	C	D	E (Pitch)	Weight/ pc	Weight/ box	Max Load
001	Ø30	M8	105	37.3	-	48g	0.48kgs	350kgs
002	Ø60	M12	105	37.3	-	115g	1.15kgs	480kgs
003	Ø80	M12	105	37.3	-	148g	1.48kgs	560kgs
004	Ø100	M12	100	44	73	237g	2.37kgs	650kgs
005	Ø40	M12	86	21.3	-	77g	0.77kgs	400kgs
006	Ø60	M8	105	37.3	-	91g	0.91kgs	480kgs



FEET

Feet (MS)



999 130 ...

Quantity/box 10
 Weight/pc 187g/ 306g
 Weight/box 1.87kgs/3.06kgs
 Swivelling range +/- 7°

Material

MS
 Includes locking nut M12

Refer Table : 59.1

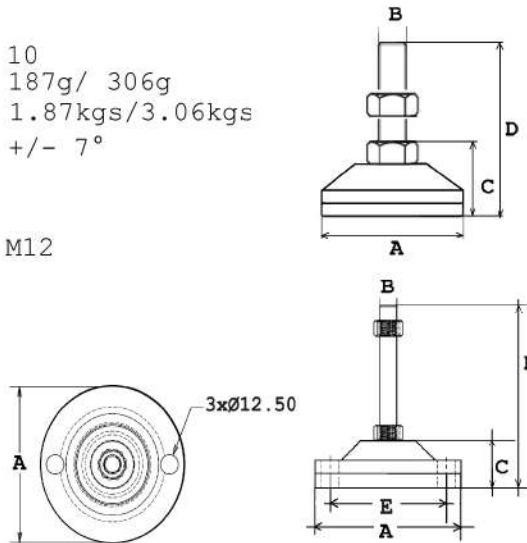

Ø40:001 Ø60:002



Ø80:003 Ø100:004



Feet (SS)



999 131 ...

Quantity/box 10
 Max.load 400kgs
 Swivelling range +/-5°

Material:

Steel, zinc plated
 PA with fibre glass
 Locking nut M12

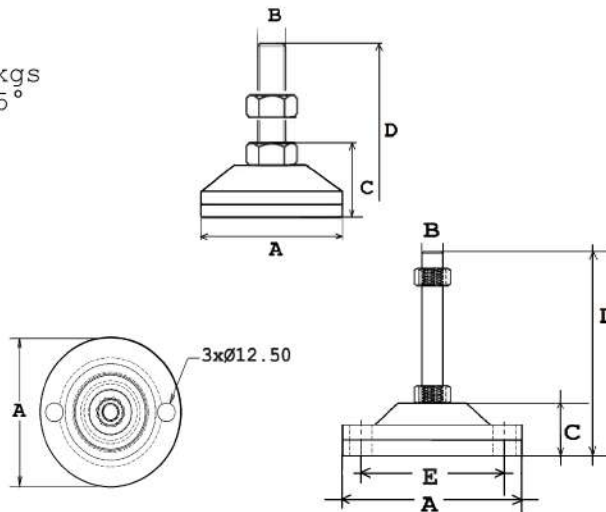

Ø40:001 Ø60:002



Ø80:003 Ø100:004



Table: 59.1

Order code	A	B	C	D	E (Pitch)	Weight/pc	Weight/box	Max Load
001	Ø40	M12	30.5	116	-	190g	1.90kgs	550kgs
002	Ø60	M12	30.5	116	-	300g	3.0kgs	640kgs
003	Ø80	M12	30.5	116	-	442g	4.42kgs	820kgs
004	Ø100	M12	30.5	116	80	549g	5.49kgs	1000kgs

FEET

999 164 ...

Feet MS With Grouting

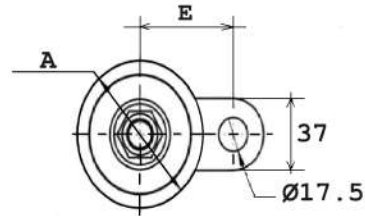

Ø60:001

Quantity/box 10
Swivelling range +/- 7°

Material
MS, Zinc Blue coated

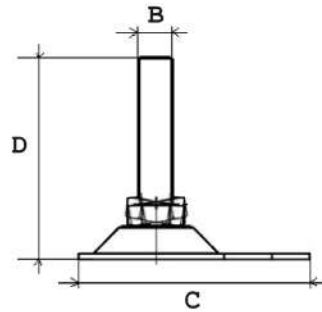

Ø76:002

Quantity/box 10
Swivelling range +/- 7°

Material
MS, Zinc Blue coated

Order code 999 131..	A	B	C	D	E	Weight/ Pc	Weight/ box	Max Load
001	Ø60	M12	100	65	56.50	0.165kgs	1.65kgs	480kgs
002	Ø76	M12	113	70	52.50	0.209kgs	2.09kgs	560kgs

CASTORS

General

Material

Wheel: Polyurethane (PUR)
 Maroon colour
 Bearing: TPFE

Application

For trolles

Advantages

Economic and easy to mount

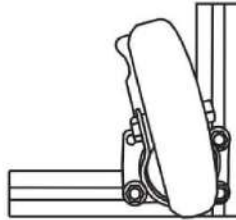

Castors Ø75 (Flange Type)



999 132 ...

With brake

Quantity/box 10
 Weight/pc 736g
 Weight/box 7.36kgs
 Max.load/wheel 110kgs

Without brake

Quantity/box 10
 Weight/pc 603g
 Weight/box 6.30kgs
 Max.load/wheel 110kgs

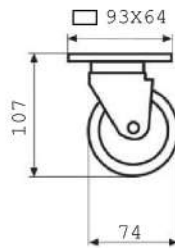

001 002



Swivel Type

Castors Ø75 (Stud Type M12X30)



999 132 ...

With brake

Quantity/box 10
 Weight/pc 647g
 Weight/box 6.47kgs
 Max.load/wheel 110kgs

Without brake

Quantity/box 10
 Weight/pc 509g
 Weight/box 5.09kgs
 Max.load/wheel 150kgs

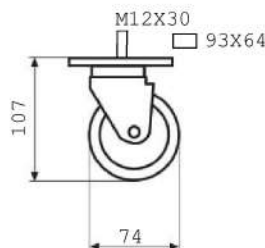

003 004



Swivel Type

Fixed Ø75



999 132 005

Quantity/box 10
 Weight/pc 424g
 Weight/box 4.24kgs
 Max.load/wheel 110kgs

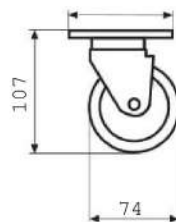

Fixed Type



999 132 ...

Castor 100Ø (Flange Type)  

:006

:007



Swivel Type

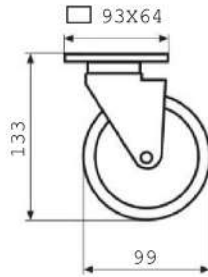

With brake :006

Quantity/box	10
Weight/pc	837g
Weight/box	8.37kgs
Max.load/wheel	130 kgs

Without brake :007

Quantity/box	10
Weight/pc	706g
Weight/box	7.06kgs
Max.load/wheel	130Kgs

3

999 132 ...

Castor 100Ø (Stud Type M12x30)  

:008

:009



Swivel Type

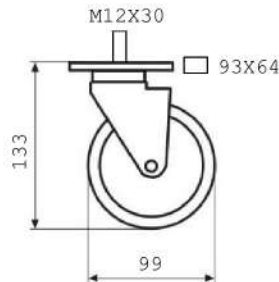



With brake :008

Quantity/box	10
Weight/pc	744g
Weight/box	7.44kgs
Max.load/wheel	130 kgs

Without brake :009

Quantity/box	10
Weight/pc	613g
Weight/box	6.13kgs
Max.load/wheel	170Kgs

999 132 010

Castor 100Ø (Fixed)  



Fixted Type

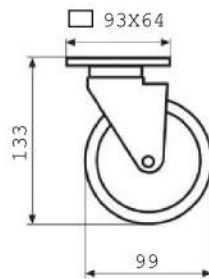

Quantity/box	10
Weight/pc	529g
Weight/box	5.29kgs
Max.load/wheel	130 kgs

Castor 125Ø (Flange Type)

999 132 ...

With brake :011

Quantity/box	10
Weight/pc	931g
Weight/box	9.31kgs
Max.load/wheel	150 kgs

Without brake :012

Quantity/box	10
Weight/pc	808g
Weight/box	8.08kgs
Max.load/wheel	150 kgs

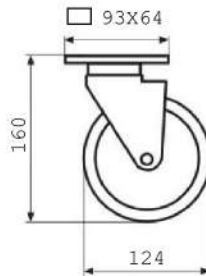

:011

:012



Swivel Type

CASTORS (FOOT MASTER)

60Ø

999 132 ...

Flange Type :013

Quantity/box	10
Weight/pc	664g
Weight/box	6.64kgs
Max.load/wheel	250kgs

Stud Type :014

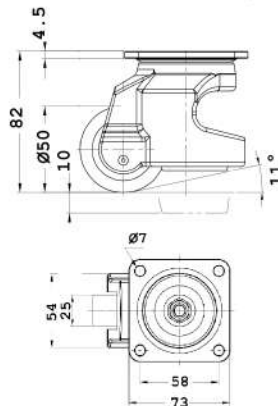

Flange Type :013



80Ø

999 132 ...

Flange Type:015

Quantity/box	10
Weight/pc	1.182kgs
Weight/box	11.82kgs
Max.load/wheel	500kgs

Stud Type:016

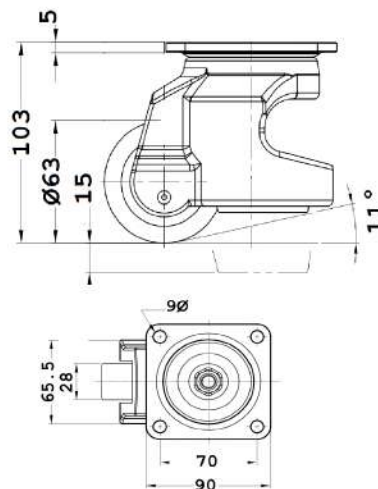

Flange Type:015



TRANSPORT- AND BASE PLATES

General



Material
Die cast aluminium

Applicatoin
To mount leveling feet, rollers, hooks or similar components.

999 133 ...

Transport & Base Plate Rectangular

Quantity/box 10

3

:001 :002 :003

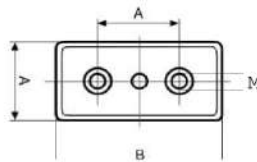

Profile Type	Order Code 999 133 ...	Bore \varnothing	M	A	B	Height	Weight/ Pc	Weight/ Box
20x40	001	9mm	M6	20mm	40mm	12mm	40g	0,40kgs
30x60	002	9mm	M12	30mm	60mm	12mm	42g	0,42kgs
40x80	003	9mm	M12	40mm	80mm	16mm	88g	0,88kgs
45x90	004	9mm	M12	45mm	90mm	16mm	108g	1.08kgs

45

999 133 ...

Transport & Base Plate Rectangular

Quantity/box 10

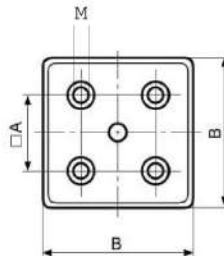

Profile Type	Order Code 999 133 ...	Bore \varnothing	M	A	B	Height	Weight/ Pc	Weight/ Box
80x80	005	9mm	M12	40mm	80mm	16mm	194g	1,94kg
90x90	006	9mm	M12	45mm	90mm	16mm	228g	2,28kg
60x60	007	9mm	M12	30mm	60mm	16mm	84 g	0,84kg

Aluminium Hinges



Page : 78

Plastic Hinges



Page : 79-80

Handles



Page : 81-83

Ball Catch/Magnet Catch



Page : 83-84

Slam Latch



Page : 84

Sliders



Page : 85

Roller



Page : 86-87

Panel
Rubber Profiles



Page : 88

Unilocks



Page : 89-90



ALUMINIUM HINGES

General



Material

Wing: Aluminium, anodized

Bolt: Stainless steel

Gap: 5mm

Application

For door made of profiles or panels

Advantages

Detachable, hidden screws, appealing design, modular

999 134 ...

Hinge Components



Quantity/box

10

Load max

150N

Kindly order each component separately

4

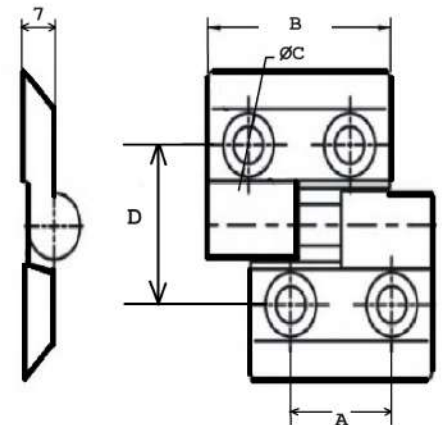
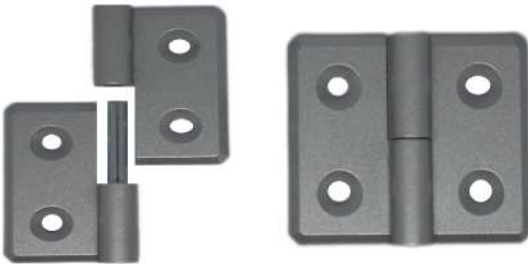

Profile Type	Order Code 999 134 ..	A	B	ØC	D	Weight/pc	Weight/Box
20X20	001	14mm	22mm	5.3mm	21mm	15g	0.15kgs
30X30	002	24mm	43mm	6.4mm	31mm	20g	0.20kgs
40X40	003	30mm	60mm	6.4mm	40mm	25g	0.25kgs
45X45	004	30mm	47mm	6.4mm	45mm	28g	0.28kgs
60X60	005	35mm	62mm	6.4mm	-	36g	0.36kgs

PLASTIC HINGES

General

Material

Wing: Fibreglass reinforced
PA black
Bolt: Stainless steel
Gap: 5mm

Application

For doors made of profiles
or panels

Advantages

Guiding lug removable

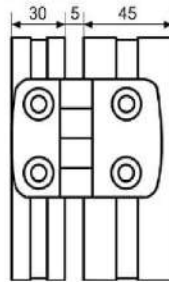

Hinge 20/20 & 30/30



999 135 ...

Order code: 20/20: 001

30/30: 002

For 30/30

Accessories not included:

4 x Countersunk screw: 999 155 001

4 x T-Nut : 999 150 005

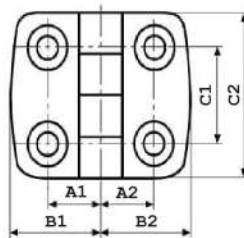

Details: Refer table 47.1

Hinge 40/40 & 45/45



999 135 ...

Order code: 40/40: 003

Order code: 45/45: 004

Accessories not included:

4 x Countersunk screw: 999 155 001

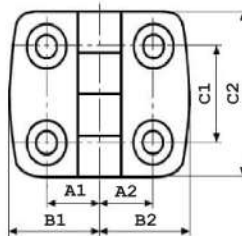

4 x T-Nut : 999 150 004



Details: Refer table 47.1

PLASTIC HINGES

999 135 008

Hinge 40/30 With cap  

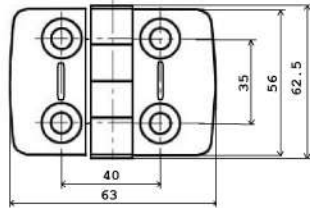

Quantity/box: 10
 Weight/pc: 46g
 Weight/box: 0,046kgs

Accessories not included:

4 x Countertsunkscrew: **999 155 001**
 4 x T-Nut : **999 150 005**

999 135 ...

Hinge 40/30& 45/30  

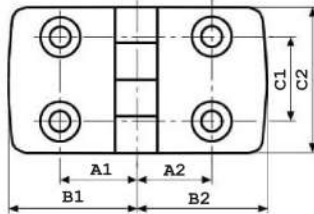

Order code: 40/30: 005
 Order code: 45/30: 006

Accessories not incl:
 2 x Countersunkscrew M6x12: **999 155 001**
 2 X T-Nut Slot 8 M6 : **999 150 005**
 2 x Countersunkscrew M6x16: **999 155 002**
 2 x T-Nut Slot 10 M6 : **999 150 008**

Details: Refer table 47.1

Table: 47.1

Article	20/20	20/30	30/30	40/30 C	40 / 30	45/30	40/40	45/45
Order code:999 135	001	007	002	008	005	006	003	004
Quantity/box	10	10	10	10	10	10	10	10
Weight/pc	7,5g	31g	33g	47g	39g	41g	38,5g	43g
Weight/box	0.0075kg	0.31kgs	0,30kg	0.47kgs	0.390kgs	0.410kgs	0,385 kgs	0,430 kgs
A1	12.5mm	17.5mm	17.5mm	17,5mm	17,5mm	17,5mm	22,5mm	25mm
A2	12.5mm	12.5mm	17.5mm	22,5mm	22,5mm	25mm	22,5mm	25mm
B1	22.5 mm	28mm	28mm	31.5mm	30mm	30mm	33.25mm	35.5mm
B2	22.5 mm	22.5mm	28mm	31.5mm	40mm	45mm	33.25mm	35.5mm
C1	23mm	23mm	23mm	35mm	23mm	28mm	23mm	23mm
C2	45mm	45mm	45mm	56mm	45mm	50.25mm	46mm	45.3mm

POLYAMIDE HANDLES

General

Application

Doors, flaps

Advantages

Front side mounting

Material

Fibreglass reinforced PA,
black

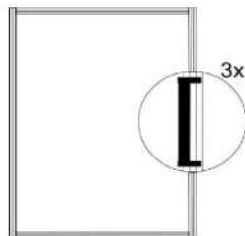

Handle, light



999 136 ...

Quantity/box 10
Weight/pc 40g
Weight/box 0,400kgs

Mounting kit
not incl:

2 x Scew M8x16 : 999 154 003
2 x T Nut M5 : 999 150 007

Available colours:

Black (RAL 9005) -001
Gray (RAL 7035) -002

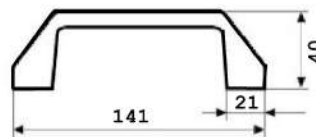
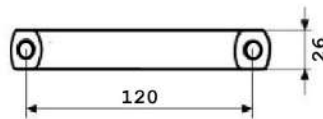

ALUMINIUM HANDLES

General

Application

Doors, flaps

Advantages

Front side mounting

Material:

Aluminium

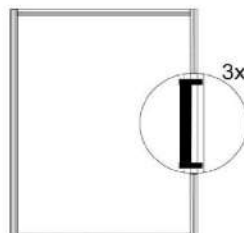

999 137 001

Handle 90 Pitch

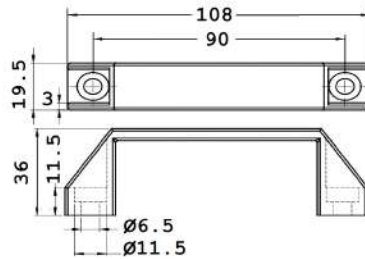

Quantity/box 10
Weight/pc 60g
Weight/box 0.6kgs

2 x Screw M6X12 : 999 154 002
2 X T nut M6 : 999 150 008

999 137 002

Handle 120 Pitch

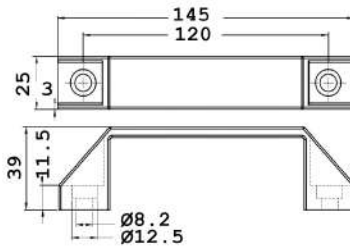

Quantity/box 10
Weight/pc 90g
Weight/box 0.9kgs

2 x Screw M6X12 : 999 154 002
2 X T nut M6 : 999 150 008

999 137 003

Handle 180 Pitch

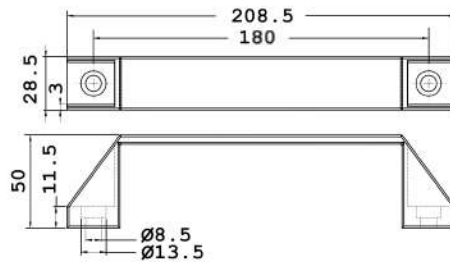

Quantity/box 10
Weight/pc 180g
Weight/box 1.80kgs

2 x Screw M6X12 : 999 154 002
2 X T nut M6 : 999 150 008

999 138 001

Design Handle



Quantity/box 1
Weight/pc 420g

Mounting kit
not incl:
2 x Screw M6X12 : 999 154 002
2 x T Nut M6 : 999 150 008

Material

Aluminium, Plastic

Colour

Aluminium/black

Advantages

Aesthetic design, ergonomic operation of double doors



Handle End - Polyamide

999 165 001

Quantity/box 10
Weight/pc 0.081kgs
Weight/box 0.81kgs

Colour :
Black

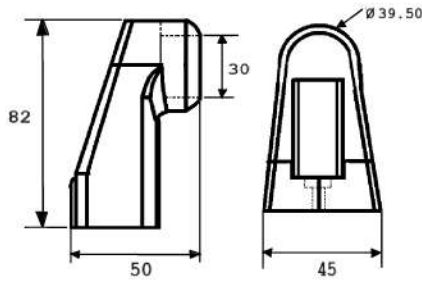

BALL CATCH / MAGNET CATCH

General

Material

Fibreglass reinforced PA,
black

Application

Catches for doors
and flaps

Advantages

Easy to use, inexpensive

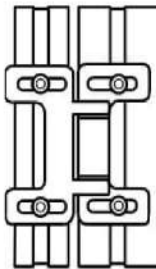

Ball Catch Type 1



999 139 001

Quantity/box 10
Weight/pc 0.050kgs
Weight/box 0,500kgs

Mounting kit
not incl:

4 x Screw M5x16 :999 154 006

4 x T Nut M5 :999 150 007

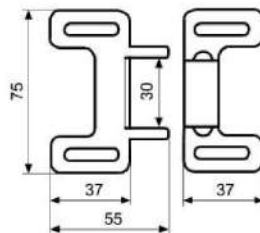

Ball catch Type 2



999 139 002

Quantity/box 10
Weight/pc 0.025 kgs
Weight/box 0.250kgs

Mounting kit
not incl:

2 x Screw M5x16 :999 154 006

2 x T Nut M5 :999 150 007

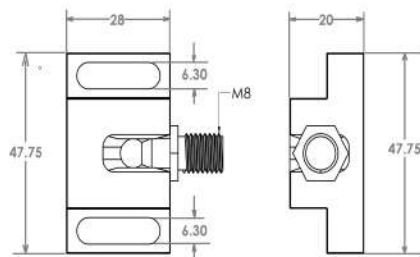

999 140 ...

Magnet Catch



Quantity/box 10
 Weight/pc 36g
 Weight/box 0,360kgs

Adjustable to the thickness of the panels

Counter plate:
 Pan head
 screw DIN 921-M5x6

Slot : 001

Slot : 002

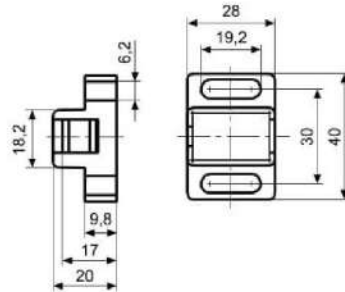

SLAM LATCHES

General

Material

Die cast aluminium,
 powder coated, black

Application

To securely lock doors & flaps
 To open just pull the latch

Advantages

Very robust and modern design
 front mounting, no drilling



4

999 141 001

Slam latch Gen 2 Black

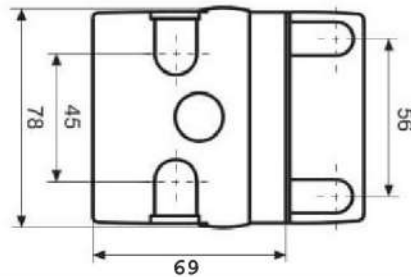

Quantity/box 1
 Weight/pc 0.236kgs
 Accessories not incl

999 141 002

Slam latch Gen 2 Gray

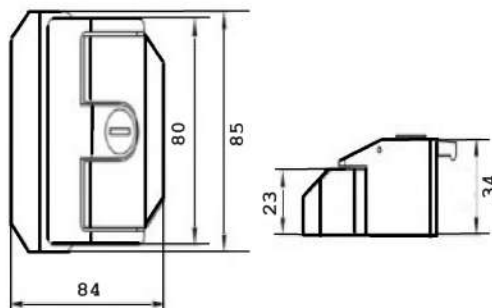

Quantity/box 1
 Weight/pc 0.563kgs
 Accessories not incl

SLIDER

General

Material

Plastic POM
white

Application

Sliding door



Slider 8

999 142 001

Quantity/box 10
Weight/pc 24g
Weight/box 0,24kgs
Length 80mm

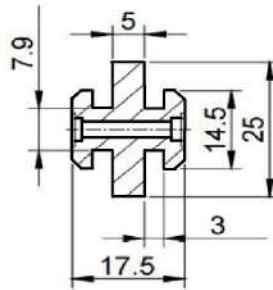

Slider 10

999 142 002

Quantity/box 10
Weight/pc 47g
Weight/box 0,47kgs
Length 80mm

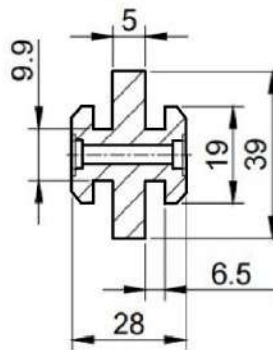

ROLLER

General

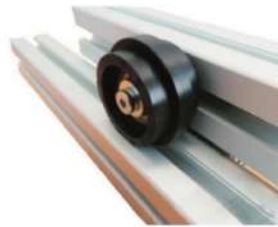

Material

Nylon PA,
Glass ball reinforced

Black
ESD

Application

For guidance in the profile
Slot 10mm
Standing or hanging

999 143 001

Roller V-Slot

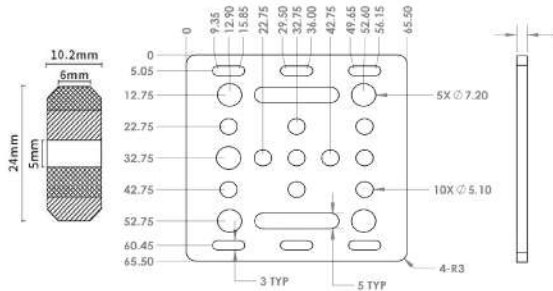

Quantity/box : 50
Weight/set : 107g
Weight/box : 5.35kgs
Only for 20x20 VSlot
Max. load : 250kgs

Material

Roller: POM
Plate: Steel, Black
powder coated

999 143 002

Roller Slot - 10

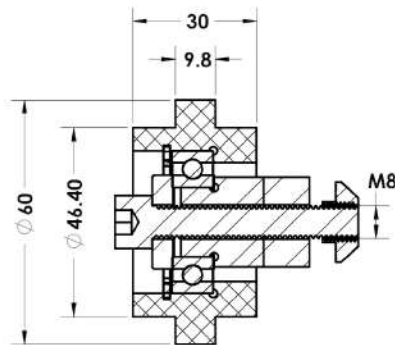

Quantity/box : 10
Weight/pc : 155g
Weight/box : 1,5kgs
Max. load : 300kgs

Accessories Included:

Screw M8X50
Washer: 5mm Thickness
T-Nut Slot10M8 : 999 150 009



Cubic Roller - Slot 10



999 143 003

Quantity/box :10
Weight/pc :0.196Kgs
Weight/box :1.96Kgs
Max. load :200kgs

Included:

2xM12X30 Central Bolt
-999 112 003

Countersunk Screw M6x40

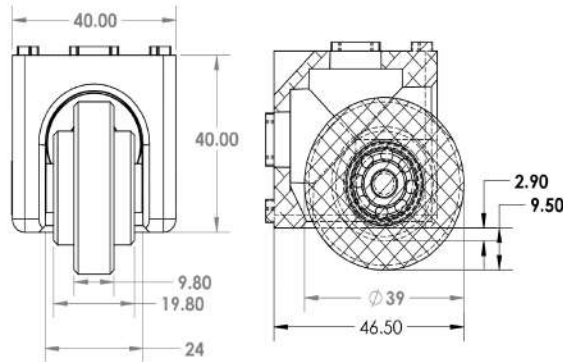

Sheet Roller - Slot 10

999 143 004

Quantity/box :10
Weight/pc :0.157kgs
Weight/box :1.57kgs
Max. load :300kgs

Included:

Allen Head Screw M8x40

Locknut M8

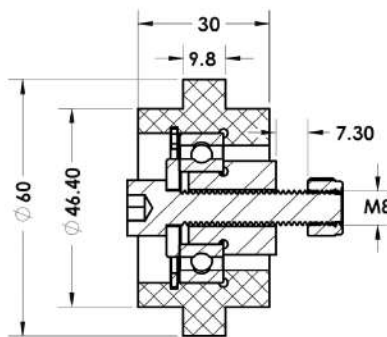

PANEL-RUBBER PROFILE

General

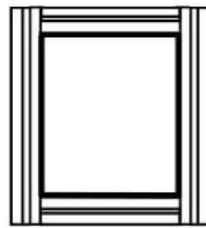
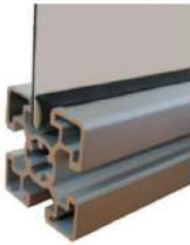

Application

To insert panels

999 144 ...

Panel profile



	001
	002
	003

Material

PP

Quantity/box	100
Weight/pc	90g/130g
Weight/box	9/13kgs
Length	2m/pc
Panel thickness	2-5mm

999 145... .

Rubber profile A/B



A: 001 B: 002



for panel thickness:

Typ Type		
A	2-3	
B	4-5	2-3

Material	Gummi/Rubber
Weight/M(A/B)	113/67g
Weight/roll (A/B)	17kgs/10kgs
Delivery unit	150m
Panel thickness	2-5mm

Advantages

Easy subsequent mounting

999 145...

Rubber profile C/D



C: 003 D: 004



for panel thickness:

Typ Type		
C	6	4
D	7	5

Material	Gummi/Rubber
Weight/M(C/D)	23/30g
Weight/roll (C/D)	3kgs/5kgs
Delivery unit	150m/300m
Panel thickness	4-7mm

Advantages

Easy subsequent mounting

UNIBLOCKS

General

Material

Block: Fibreglass reinforced, PA black
Nut: M6; Steel, zinc coated

Application

To mount a panel onto the profile, position is adjustable.
insert into the slot and turn 90°
Nut height is adjustable

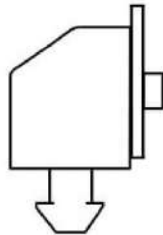

Uniblock 8



999 146 001

Quantity/box 100
Weight/pc 11g
Weight/box 1,10kgs

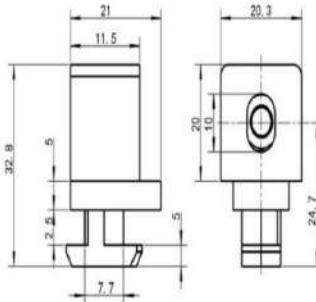

Uniblock 10



999 146 002

Quantity/box 100
Weight/pc 12g
Weight/box 1,20kgs

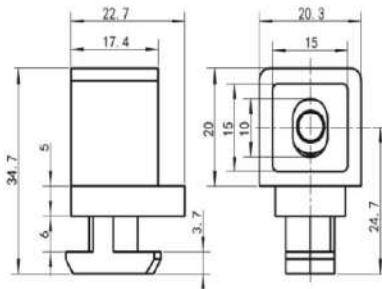

UNIBLOCKS

999 146 003	Uniblock 6	
-------------	------------	--

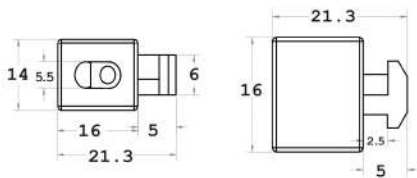

Quantity/box	100
Weight/pc	0.004kgs
Weight/box	0.400Kgs

999 146 004	Uniblock 8	
-------------	------------	--

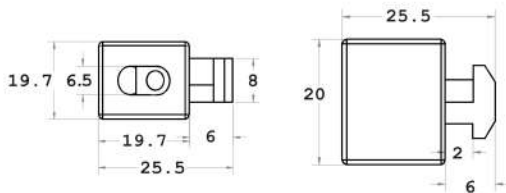

Quantity/box	100
Weight/pc	0.009kgs
Weight/box	0.9kgs

4

999 146 005	Uniblock 10	
-------------	-------------	--

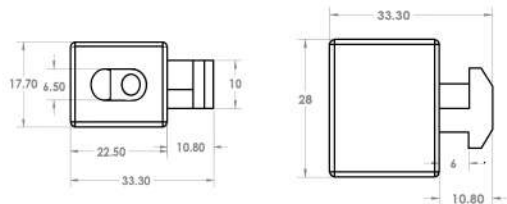

Quantity/box	100
Weight/pc	0.013kgs
Weight/box	1.3kgs

Tool Hanger



Page: 92

Work Tables



Page: 93-95

TOOL HANGER

General

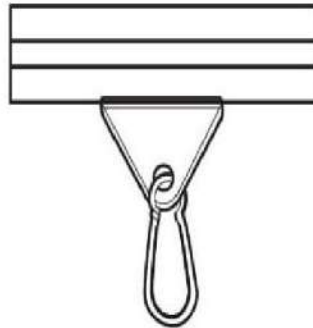

Application

Sliding tool hanger for balancers with option to lock into fixed position.

999 147 ...

Tool hanger



:001



:002

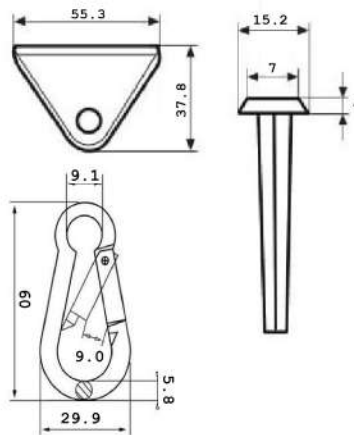

Tool Hanger : 001

Quantity/box 50
Weight/ 0.007kgs
Weight/box 0.350kgs

Material

Poloxymethylene (POM)
black:

Snap Hook : 002

Quantity/box 50
Weight/ 0.023kgs
Weight/box 1.15kgs

Material

Poloxymethylene (POM)
black:

Hook:Steel

Load/kg : 70kg

Advantages

Inexpensive and easy-to-use.

WORK TABLES

Ergonomics Work Table

999 166 ...

Types :

1. Worktable Siting Type
2. Worktable Standing Type

Our table frames with fixed working height are made from 40 profiles standard dimensions shown here allow it to be used as sit-to-stand Workstation.

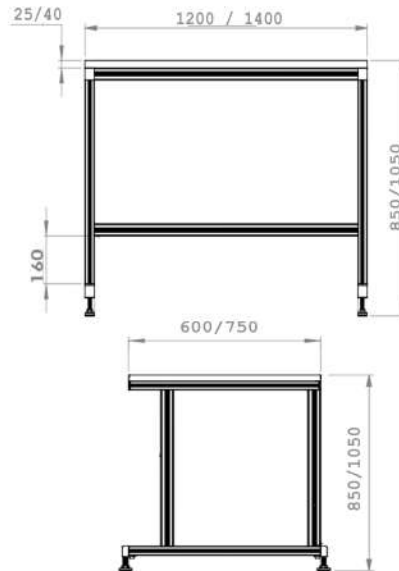

S.NO	Description	Dimensions	Cover Profile & Cover Cap Black	Cover Profile & Cover Cap Blue	Cover Profile & Cover Cap Gray	Cover Profile & Cover Cap Red	Cover Profile & Cover Cap Yellow	Cover Profile & Cover Cap Orange	Max Load
1	Si Table (Plywood)	1200x600x850, 25mm	999 166 001	999 166 002	999 166 003	999 166 004	999 166 005	999 166 006	2000N
2	Si Table (Particle Board)	1200x600x850, 25mm	999 166 007	999 166 008	999 166 009	999 166 010	999 166 011	999 166 012	2000N
3	Si Table (Plywood)	1200x600x850, 40mm	999 166 013	999 166 014	999 166 015	999 166 016	999 166 017	999 166 018	4000N
4	Si Table (Particle Board)	1200x600x850, 40mm	999 166 019	999 166 020	999 166 021	999 166 022	999 166 023	999 166 024	4000N
5	St Table (Plywood)	1400x750x1050, 25mm	999 166 025	999 166 026	999 166 027	999 166 028	999 166 029	999 166 030	2000N
6	St Table (Particle Board)	1400x750x1050, 25mm	999 166 031	999 166 032	999 166 033	999 166 034	999 166 035	999 166 036	2000N
7	St Table (Plywood)	1400x750x1050, 40mm	999 166 037	999 166 038	999 166 039	999 166 040	999 166 041	999 166 042	4000N
8	St Table (Particle Board)	1400x750x1050, 40mm	999 166 043	999 166 044	999 166 045	999 166 046	999 166 047	999 166 048	4000N

Si : Sitting Table
St : Standing Table

ADJUSTABLE WORK TABLES

999 167 ...

Adjustable Worktable

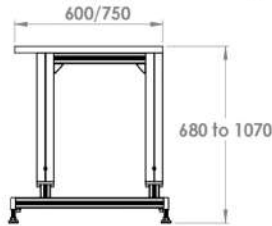
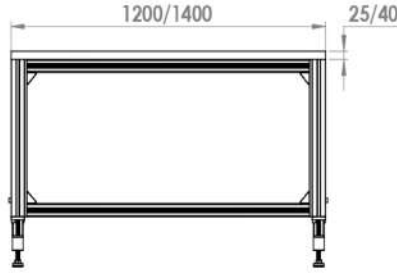

Types :

1. Adjustable Worktable sitting
2. Adjustable Worktable Standing

Our table frames with adjustable height are made with 40 profile and telescopic profile, Dimensions shown below

S.NO	Description	Dimensions	Cover Profile	Cover Profile	Cover Profile	Cover Profile	Cover Profile	Cover Profile	Max Load
1	Adj Si Table -Plywood	1200x600x680 to 1070, 25mm	999 167 001	999 167 002	999 167 003	999 167 004	999 167 005	999 167 006	2000N
2	Adj Si Table -Particle Board	1200x600x680 to1070, 25mm	999 167 007	999 167 008	999 167 009	999 167 010	999 167 011	999 167 012	2000N
3	Adj Si Table -Plywood	1200x600x680 to1070, 40mm	999 167 013	999 167 014	999 167 015	999 167 016	999 167 017	999 167 018	4000N
4	Adj Si Table -Particle Board	1200x600x680 to1070, 40mm	999 167 019	999 167 020	999 167 021	999 167 022	999 167 023	999 167 024	4000N
5	Adj St Table -Plywood	1400x750x680 to1070, 25mm	999 167 025	999 167 026	999 167 027	999 167 028	999 167 029	999 167 030	2000N
6	Adj St Table -Particle Board	1400x750x680 to1070, 25mm	999 167 031	999 167 032	999 167 033	999 167 034	999 167 035	999 167 036	2000N
7	Adj St Table -Plywood	1400x750x680 to1070, 40mm	999 167 037	999 167 038	999 167 039	999 167 040	999 167 041	999 167 042	4000N
8	Adj St Table -Particle Board	1400x750x680 to1070, 40mm	999 167 043	999 167 044	999 167 045	999 167 046	999 167 047	999 167 048	4000N

Si : Sitting Table
 St : Standing Table
 Adj: Adjustable

RISERS

Riser

999 171 ...

Quantity/Box : 1
 Weight/Pc : 2.7kgs
 Weight/Box : 4.27kgs

Risers are used for mounting additional parts above the table top. The height of the riser can be adjusted with the help of 40x40 bracket.

Accessories not Included:
 Tubelight

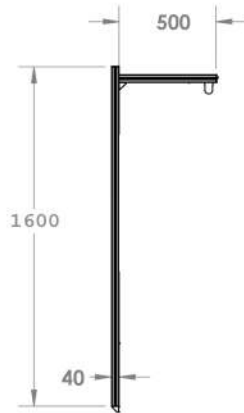

S.NO	Description	Dimensions	Cover Profile & Cover Cap Black	Cover Profile & Cover Cap Blue	Cover Profile & Cover Cap Gray	Cover Profile & Cover Cap Red	Cover Profile & Cover Cap Yellow	Cover Profile & Cover Cap Orange	Max Load
1	Riser	1600x500	999 171 001	999 171 002	999 171 003	999 171 004	999 171 005	999 171 006	200N Permissible



NOTES

**T Bolts
Flange Nut**



Page : 98-100

T Nuts



Page : 100-101

**T Slot Nuts
Roll-in T-Slot Nuts
Rhombus Nut**



Page : 101-102

Screws



Page : 105

Cable Binders



Page : 107

T-BOLTS

General



Material

Steel, zinc plated

Application

M8x20:
Bracket 40, floor bracket
M8x25:
Bracket 45x45, 40x80
90x90

999 148...

T Bolt 8



M6X16:001

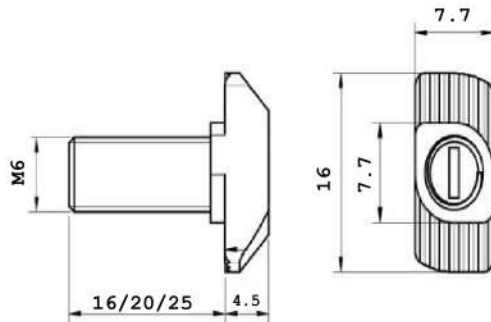

M6X16:001

Quantity/box 100
Weight/pc 0.007kgs
Weight/box 0.7kgs

M6X20:007



M6X20:007

Quantity/box 100
Weight/pc 0.009kgs
Weight/box 0.9kgs

M6X25:008



M6X25:008

Quantity/box 100
Weight/pc 0.012kgs
Weight/box 1.2kgs

FIXING ,INSTALATION MATERIAL

T Bolt 10



999 148...

M8x20

Quantity/box 100
 Weight/pc 13g
 Weight/box 1,3kgs
 For bracket: 40x40,
 Floor mounting bracket

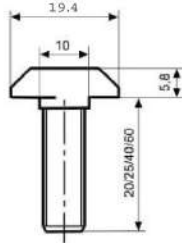

M8x25

Quantity/box 100
 Weight/pc 14,2g
 Weight/box 1.42kgs

For brackets: 45x45, 40x80
 45x90, 90x90

M8x30

Quantity/box 100
 Weight/pc 16,3g
 Weight/box 1,63kgs

M8x40

Quantity/box 50
 Weight/pc 19,4g
 Weight/box 1,94kgs

M8x60

Quantity/box 50
 Weight/pc 25,5g
 Weight/box 2,55kgs

M8x20:002



M8x25:003



M8x30:004



M8x40:005



M8x60:006



999 149 ...

Flange Nut M8

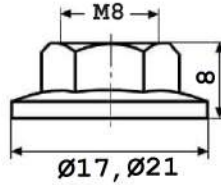

Flange Size (Ø17):001
Flange Size (Ø21):002

Quantity/box	100
Ø17	
Weight/pc	6.72gms
Weight/box	0.672kgs
Ø21	
Weight/pc	10.34gms
Weight/box	1.034kgs
Class	8
Wrench size	13mm

Application:

For fixing T bolt/bracket onto a profile

T NUT (HAMMER NUT)

General

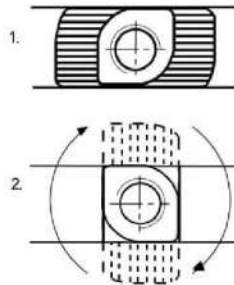

Material

Steel, zinc plated

Application

To fix components to profiles can be inserted into a closed frame.

Advantages

safe and conductive connection

999 150 ...

T Nut (Hammer nut)



6

M3: 010



M4: 001



M5: 002

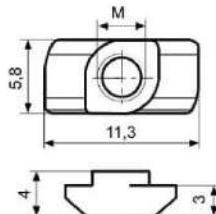

Quantity/box	100
--------------	-----

M4

Weight/pc	1.28gms
Weight/box	0.128kgs

M5

Weight/pc	1.11gms
Weight/box	0.111kgs

T Nut (Hammer nut)

999 150 ...

Quantity/box 100

M4
Weight/pc 4.21gms
Weight/box 0.421kgs

M5
Weight/pc 3.96gms
Weight/box 0.396kgs

M6
Weight/pc 3.69gms
Weight/box 0.369kgs

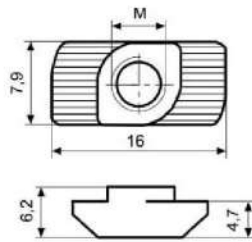

M3:011

M4:003



M5:004

M6:005



T Nut (Hammer nut)

999 150 ...

Quantity/box 100

M4
Weight/pc 8.27gms
Weight/box 0.827kgs

M5
Weight/pc 8.18gms
Weight/box 0.818kgs

M6
Weight/pc 7.77gms
Weight/box 0.777kgs

M8
Weight/pc 6.62gms
Weight/box 0.662kgs

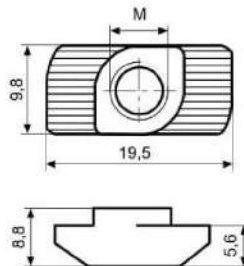

M4:006

M5:007



M6:008

M8:009



Slot Nut (SQ Nut)

999 151 ...

Quantity 100

M4
Weight/pc 2.2gms
Weight/box 0.220kgs

M5
Weight/pc 2.4gms
Weight/box 0.240kgs

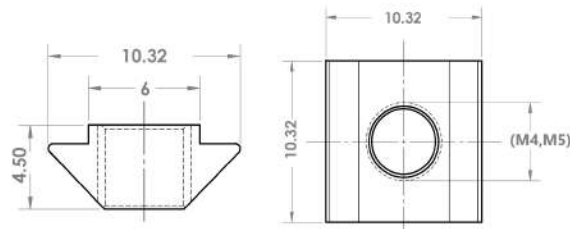

M4:001



M5:002

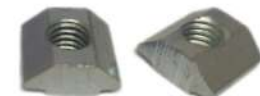

999 151 ...

Slot Nut (SQ Nut)

M4:003

M5:004

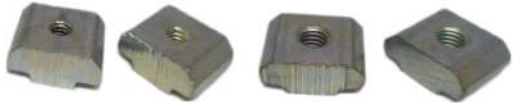

M6:005

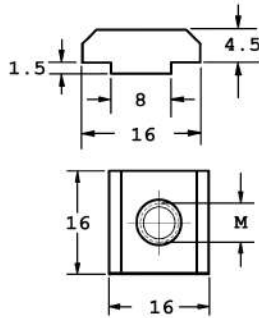

Quantity	100
M4	
Weight/pc	9.57gms
Weight/box	0.957kgs
M5	
Weight/pc	9.30gms
Weight/box	0.93kgs
M6	
Weight/pc	9.01gms
Weight/box	0.901kgs

999 151 ...

Slot Nut (SQ Nut)

M4:006

M5:007



M6:008

M8:009

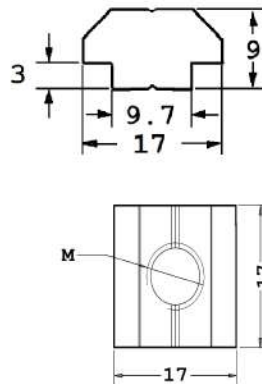

Quantity/box	100
M4	
Weight/pc	15.23gms
Weight/box	1.523kgs
M5	
Weight/pc	14.86gms
Weight/box	1.486kgs
M6	
Weight/pc	14.45gms
Weight/box	1.445kgs
M8	
Weight/pc	13.27gms
Weight/box	1.327kgs

999 152 ...

Rhombus Nut

M4:001

M5:002

M6:003

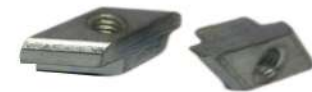

M8:004

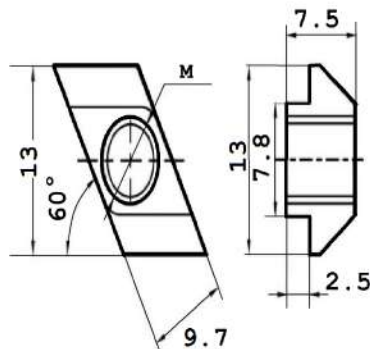

M6	
Quantity/box	100
Weight/pc	8g
Weight/box	0.8kgs

M8	
Quantity/box	100
Weight/pc	6g
Weight/box	0.6kgs

Application

To make solid connections to profiles; to be inserted before closing the frame

Roll-in T Slot Nut

999 153 ...

M4:001

Quantity/box 100
Weight/pc 0.004kgs
Weight/box 0.4kgs

M5:002

Quantity/box 100
Weight/pc 0.004kgs
Weight/box 0.4kgs

M6:003

Quantity/box 100
Weight/pc 0.004kgs
Weight/box 0.4kgs

M8:004

Quantity/box 100
Weight/pc 0.004kgs
Weight/box 0.4kgs

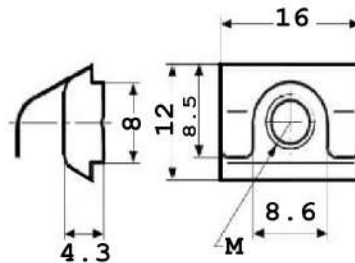

M4:001



M5:002



M6:003



M8:004



Application

To make solid connections,
Can be rolled-in also into a
closed structure, with
-aligning support

Roll-in T Slot Nut

999 153 ...

M4:005

Quantity/box 100
Weight/pc 0.009kgs
Weight/box 0.9kgs

M5:006

Quantity/box 100
Weight/pc 0.008kgs
Weight/box 0.8kgs

M6:007

Quantity/box 100
Weight/pc 0.008kgs
Weight/box 0.8kgs

M8:008

Quantity/box 100
Weight/pc 0.007kgs
Weight/box 0.7kgs

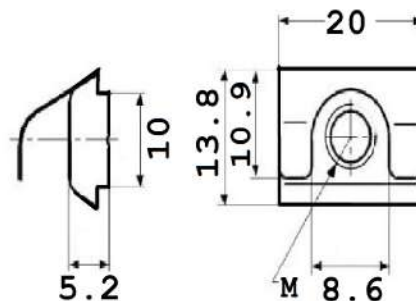

M4:005



M5:006



M6:007



M8:008





NOTES

Screw



999 154 ...

Quantity/box 500

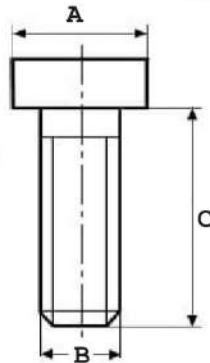

M4x8:001

M6x12:002



M8x16:003

M8x20:004



Order code 999 154...	Description	A	B	C	Weight/ Pc	Weight/ box
001	M4x8	Ø 7	M4	8 MM	1g	0.5kgs
002	M6x12	Ø 10	M6	12 MM	4g	2 kgs
003	M8x16	Ø 13	M8	16MM	10g	5 kgs
004	M8x20	Ø 13	M8	20MM	11g	5.5kgs
005	M5x8	Ø8.5	M5	8MM	2g	1 kgs
006	M5x16	Ø8.5	M5	16MM	4g	2kgs
007	M6x16	Ø10	M6	16MM	5g	2.5kgs

M5x8:005 M5x16:006 M6x16:007



Countersunk screw



999 155 ...

Material: Stainless steel

Quantity/box 200

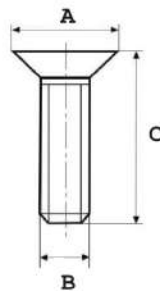

Order code 999 131..	Description	A	B	C	Weight/ Pc	Weight/ box
001	M6X12	Ø12	M6	12MM	3.4g	0.68kgs
002	M6X16	Ø12	M6	16MM	4.1g	0.82kgs
003	M5X20	Ø10	M5	20MM	3.5g	0.70 kgs
004	M8X25	Ø16	M8	25MM	11.7g	2.34kgs
005	M8X30	Ø16	M8	30MM	13.7g	2.74kgs

General



Reducers convert a
M12 (M12X1.75)
threaded hole to a
M8 (M8X1.25) & (M6X1)
threaded hole.

To assist in installation and removal, each thread reducer has a slot on the top for use with a flathead screwdriver.

999 162 ...

Reducer

M12 To M8 : 001



M12 To M6 : 002

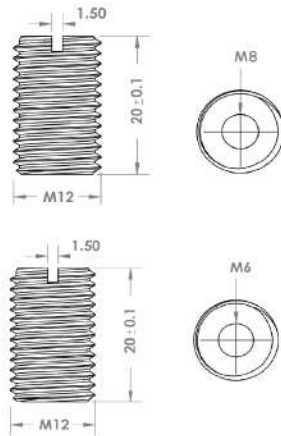

M12 To M8 : 001

Quantity/box	100
Weight/pc	0.012kgs
Weight/box	1.2kgs
Material:	Steel, Zinc plated

M12 To M6 : 002

Quantity/box	100
Weight/pc	0.009kgs
Weight/box	0.900 kgs
Material:	Steel, Zinc plated

Advantages:

Can use with M12 Tap in profiles with M8 & M6 Screw

CABLE BINDERS

General

Material

Fibreglass reinforced PA,
black colour

Application

To fix cables and pneumatic hoses onto profiles, position is adjustable. Just insert into the slot and turn 90°

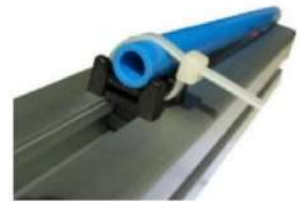
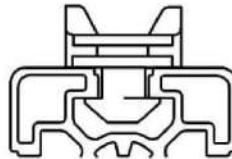

Cable binder 8



999 156 001

Quantity/box 100
Weight/pc 4g
Weight/box 0,4kgs

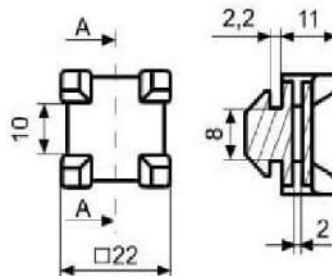

Cable binder 10



999 156 002

Quantity/box 100
Weight/pc 4,5g
Weight/box 0,45kgs

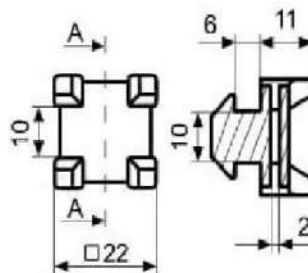

Grinder Stone



Page : 109

Forming Tool



Page : 109

Drilling Device



Page : 109

Profile Cutting Machine



Page : 110

Grinder Stone



999 157 001

Quantity/box 5
 Weight/pc 19g
 Weight/box 95g

Application

Removal of minor scratches and cleaning on aluminium profile.

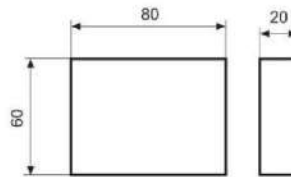

M8 & M12 Forming Tool

999 158 001

Quantity/box 1
 Weight/pc 34g

Application

Tool for self tapping bush
 Core \varnothing 7.4mm

M8:001



M12:002



Drilling Device



999 159 001

Quantity/box 1
 Weight/pc 260g

Application

For centered bores at the correct distance

\varnothing A: 8,0mm
 \varnothing B: 11,0mm



Drilling Device



999 159 002

Quantity/box 1
 Weight/pc 300g

Application

For centered bores at the correct distance

\varnothing A: 8,0mm
 \varnothing B: 17,0mm



999 160 ...

Profile Cutting Machine



Technical Parameters

Model	001-12"	002-14"	003-16"	004-18"
Input Power	1.1KW	1.5KW	2.2KW	3.0KW
Voltage	380V/50Hz 220V/50Hz	380V/50Hz 220V/50Hz	380V/50Hz 220V/50Hz	380V/50Hz 220V/50Hz
Motor Rotary Speed	2800r/min	2800r/min	2800r/min	2800r/min
Blade Specification	Φ305xΦ25.4	Φ355xΦ25.4	Φ405x25.4	Φ455x25.4
Cutting Angle	45°~90°~ -45°	45°~90°~ -45°	45°~90°~ -45°	45°~90°~ -45°
Cutting Width x Height	130x95mm (90°)	160x110mm (90°)	180x125mm (90°)	200x150mm (90°)
	95x95 (45°)	110x110mm (45°)	130x125mm (45°)	140x150mm (45°)
Overall Dimension	650x560x7250mm	600x660x7250mm	750x760x7250mm	750x760x7250mm
Weight	135kg	150kg	180kg	195kg

5 Mistakes to avoid while using aluminium profiles

You can make several mistakes with aluminium profiles, which leads to a weak and unstable assembly. Below you will find 5 most common mistakes you should avoid in order to achieve the optimally stiff and light assembly.

1.) Incorrect positioning of aluminium profiles

When connecting vertically positioned aluminium profiles with horizontally positioned aluminium profiles, the horizontal ones should always be fastened to the vertical one like in the picture below, Connecting two horizontal profiles on top of a vertical one will result in a weak profile assembly.



2.) Unsupported Joint

When two horizontal aluminium profiles are butt-fastened together, you should always support the joint.



3.) Incorrect "breaking" of profile lines

If you have longer line in the assembly, you must always use an uninterrupted aluminium profiles. Shorter profiles should be fastened to a longer profile. Otherwise, it will result in an unstable profile assembly.

An example is shown in the Picture bellow.

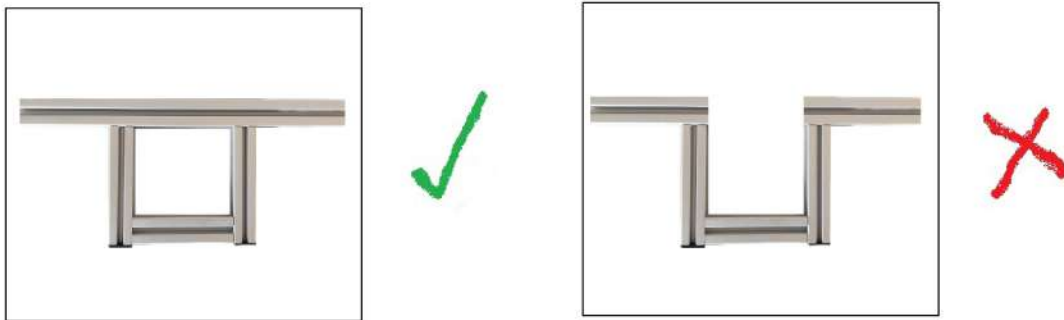

4.) Cutting threads into profiles



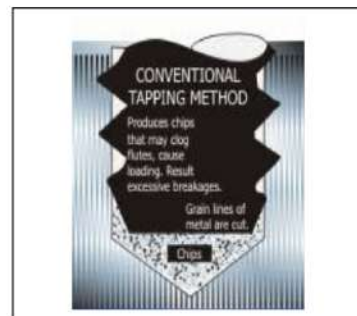



In order to ensure maximum load ratings, the threads of the aluminium profiles should be rolled as opposed to cut. Rolling will result in a 30 percent stronger thread and consequently a stronger joint.



5.) Incorrect choice of bolt connectors

For connecting aluminium assembly profiles, a wide variety of bolt connectors is available, which differs in the properties in terms of carrying capacity, ease of use, assembly times... The most popular is the use of brackets and corresponding nuts and screws, which is not always the most optimal choice.

When choosing the most optimal connector the table below may help you.

	Quick Connector 	Bracket 	Inner Bracket 	Bolt Connector 	Connection Screw 
Flexibility of Usage	5	5	2	2	3
Adjustability	5	5	3	1	1
Frame Stiffness	4	4	2	5	5
Vibration Resistance	4	2	1	5	5
Space Requirement	5	2	5	4	5
Assembly Time	5	5	4	1	4
Cost Effectiveness	4	5	4	2	4
Aesthetic Finish	5	1	5	5	5



NOTES



NOTES



NOTES



999....	S./P	999....	S./P	999....	S./P	999....	S./P	999....	S./P	999....	S./P	999....	S./P
100 001	5	102 002	26	102 068	26	106 007	40	122 004	59	133 007	76	150 011	101
100 002	5	102 003	26	102 069	26	106 008	41	122 005	59	134 001	78	151 001	101
100 003	6	102 004	26	102 070	27	107 001	41	122 006	59	134 002	78	151 002	101
100 004	6	102 005	26	102 071	27	107 002	41	122 007	59	134 003	78	151 003	102
100 005	7	102 006	26	102 072	27	107 003	42	122 008	57	134 004	78	151 004	102
100 006	7	102 007	26	102 073	27	107 004	42	122 009	58	134 005	78	151 005	102
100 007	8	102 008	26	102 074	27	108 001	41	122 010	58	135 001	79	151 006	102
100 008	8	102 009	27	102 075	27	108 002	41	122 011	58	135 002	79	151 007	102
100 009	8	102 010	27	102 076	28	108 003	42	123 001	60	135 003	79	151 008	102
100 010	9	102 011	27	102 077	28	108 004	42	123 002	60	135 004	79	151 009	102
100 011	9	102 012	27	102 078	28	109 001	43	124 001	61	135 005	80	152 001	102
100 012	10	102 013	27	102 079	28	109 002	43	124 002	61	135 006	80	152 002	102
100 013	10	102 014	27	102 080	28	109 003	43	124 003	62	135 007	-	152 003	102
100 014	10	102 015	27	102 081	28	110 001	44	124 004	61	135 008	80	152 004	102
100 015	11	102 016	27	102 082	29	110 002	44	124 005	62	136 001	81	153 001	103
100 016	11	102 017	27	102 083	29	110 003	44	125 001	64	136 002	81	153 002	103
100 017	11	102 018	27	102 084	29	111 001	44	125 002	64	137 001	82	153 003	103
100 018	12	102 019	27	102 085	29	112 001	45	126 001	65	137 002	82	153 004	103
100 019	12	102 020	27	102 086	29	112 002	45	126 002	65	137 003	82	153 005	103
100 020	12	102 021	28	102 087	29	112 003	45	126 003	66	138 001	82	153 006	103
100 021	13	102 022	28	102 088	30	112 004	45	126 004	66	139 001	83	153 007	103
100 022	13	102 023	28	102 089	30	112 005	45	126 005	66	139 002	83	153 008	103
100 023	13	102 024	28	102 090	30	112 006	45	126 006	66	140 001	84	154 001	105
100 024	14	102 025	28	102 091	30	112 007	45	126 007	66	140 002	84	154 002	105
100 025	14	102 026	28	102 092	30	113 001	45	126 008	67	141 001	84	154 003	105
100 026	14	102 027	28	102 093	30	113 002	45	126 009	67	141 002	84	154 004	105
100 027	15	102 028	28	102 094	31	114 001	46	126 010	65	142 001	85	154 005	105
100 028	15	102 029	28	102 095	31	114 002	46	127 001	68	142 002	85	154 006	105
100 029	16	102 030	28	102 096	31	114 003	46	128 001	68	143 001	86	154 007	105
100 030	16	102 031	28	102 097	31	114 004	46	128 002	68	143 002	86	155 001	105
100 031	16	102 032	28	103 001	33	114 005	47	129 001	70	143 003	87	155 002	105
100 032	17	102 033	28	103 002	33	114 006	47	129 002	70	143 004	87	155 003	105
100 033	17	102 034	29	103 003	34	114 007	47	129 003	70	144 001	88	155 004	105
100 034	6	102 035	29	103 004	34	114 008	47	129 004	70	144 002	88	155 005	105
100 035	9	102 036	29	103 005	34	115 001	48	129 005	70	144 003	88	156 001	107
100 036	7	102 037	29	103 006	35	115 002	48	129 006	70	145 001	88	156 002	107
100 037	15	102 038	29	103 007	35	115 003	48	130 001	71	145 002	88	157 001	109
100 038	5	102 039	29	103 008	35	115 004	48	130 002	71	145 003	88	158 001	109
100 040	22	102 040	29	103 009	36	115 005	48	130 003	71	145 004	88	158 002	109
100 041	20	102 041	29	103 010	36	116 001	49	130 004	71	146 001	89	159 001	109
100 042	16	102 042	29	103 011	36	116 002	49	131 001	71	146 002	89	159 002	109
100 043	12	102 043	29	104 001	33	116 003	49	131 002	71	146 003	90	160 001	110
100 044	18	102 044	29	104 002	33	116 004	49	131 003	71	146 004	90	160 002	110
100 045	6	102 045	29	104 003	34	116 005	49	131 004	71	146 005	90	160 003	110
100 046	10	102 046	30	104 004	34	116 006	49	132 001	73	147 001	92	160 004	110
100 047	14	102 047	30	104 005	34	117 001	50	132 002	73	147 002	92	162 001	106
100 048	23	102 048	30	104 006	35	117 002	50	132 003	73	148 001	98	162 002	106
101 001	25	102 049	30	104 007	35	118 001	51	132 004	73	148 002	99	164 001	72
101 002	25	102 050	30	104 008	35	118 002	51	132 005	73	148 003	99	164 002	72
101 003	25	102 051	30	104 009	36	118 003	52	132 006	74	148 004	99	165 001	83
101 004	25	102 052	30	104 010	36	118 004	52	132 007	74	148 005	99	166 001	93
101 005	25	102 053	30	104 011	36	118 005	52	132 008	74	148 006	99	166 002	93
101 006	25	102 054	30	105 001	39	118 006	53	132 009	74	148 007	98	166 003	93
101 007	25	102 055	30	105 002	39	118 007	53	132 010	74	148 008	98	166 004	93
101 008	25	102 056	30	105 003	39	118 008	53	132 011	75	149 001	100	166 005	93
101 009	25	102 057	30	105 004	40	119 001	54	132 012	75	149 002	100	166 006	93
101 010	25	102 058	31	105 005	40	119 002	54	132 013	75	150 001	100	166 007	93
101 011	25	102 059	31	105 006	40	119 003	54	132 014	75	150 002	100	166 008	93
101 012	25	102 060	31	105 007	40	120 001	55	132 015	75	150 003	101	166 009	93
101 013	25	102 061	31	105 008	41	121 001	56	132 016	75	150 004	101	166 010	93
101 014	25	102 062	31	106 001	39	121 002	56	133 001	76	150 005	101	166 011	93
101 015	25	102 063	31	106 002	39	121 003	55	133 002	76	150 006	101	166 012	93
101 016	25	102 064	31	106 003	39	121 004	55	133 003	76	150 007	101	166 013	93
101 017	25	102 065	31	106 004	40	122 001	57	133 004	76	150 008	101	166 014	93
101 018	25	102 066	26	106 005	40	122 002	57	133 005	76	150 009	101	166 015	93
102 001	26	102 067	26	106 006	40	122 003	58	133 006	76	150 010	100	166 016	93



Aluminium Profile System



Reach us at:

DEXTEROUS (AUTOMATION APT)

#51B, Bommasandra Industrial Area
Phase 1, Hosur Rd, Opp. Continental,
Bangalore, Karnataka, INDIA- 560099.

Marketing Head : +91 87222 72222
Accounts HOD : +91 76195 28179
Office : +91 96861 76179
Managing Director : +91 96635 28179
Email : info@dexterousaluminiumprofile.com
www.dexterousaluminiumprofile.com